

The Real Time Monitoring System and Early Detection of Unbalanced Load for the Three Phase Distribution Systems in Urban Areas

by Protek Unkhair

Submission date: 09-Jan-2023 07:24AM (UTC+0300)

Submission ID: 1911032819

File name: 5623-15003-1-RV.docx (699.81K)

Word count: 3751

Character count: 20659

The Real Time Monitoring System and Early Detection of Unbalanced Load for the Three Phase Distribution Systems in Urban Areas

15 Syarifuddin Nojeng¹⁾, Arif Jaya¹⁾, Reny Murniati²⁾
*1). Department of Electrical Engineering, Faculty of Engineering - Universitas Muslim Indonesia,
*2). Department of Electrical Engineering, Faculty of Engineering Universitas Sawerigading Makassar
Email: syarifuddinnojeng@umi.ac.id, arifjaya@umi.ac.id, renymurniati50@gmail.com

Abstract

This paper introduces a three-phase unbalanced load condition monitoring system in a power distribution network that can monitor and provide early warning. The distribution system is a component of the power system that must always be monitored in maintaining the service of providing electricity to customers. Currently, many technologies are applied to the distribution system that can ensure the operation of the distribution network, especially distribution transformers to determine real time transformer conditions so that damage and power losses can be minimized, but do not provide early detection. Therefore, the role of information technology is currently one of the investments that must be made for all electric power supply operators in maintaining the performance of distribution transformers through early detection. In this study, the system developed based on Internet of Things (IoT) technology that was built consists of: embedded system devices that function to carry out measurements and transmit data, Web Service software that functions to receive data from sensor systems and Arduino-based software using the Blynk Cloud application platform in presenting data and managing data through Android display devices (HP/Laptop). The Blynk is a compatible platform for applications on Mobile OS (iOS and Android) in controlling Arduino, Raspberry Pi, or ESP8266-based modules, as well as similar modules via the Internet (IoT). This system was built to provide an early warning function against network parameter anomalies such as overload, overvoltage and unbalance load. After getting the data, the system will perform calculations to obtain recommendations for system optimization in the form of balancing, maintenance or load maneuver. Based on testing, the time needed to send and receive notifications on smartphone users via the blynk application ranges from 3-4 seconds. By setting a tolerance limit of 20%, when the load is severely unbalanced where the neutral current is almost equal to or greater than the phase current, the local indicator light will light up and the Android system will provide an unbalanced load indicator.

Keywords: *Distribution System, Real Time, Early Detection, Monitoring, IoT, Losses*

1. INTRODUCTION

The electric power distribution system as the heart of the electricity supply industry is a very important component in supporting the supply of electrical energy. With the increasing need for electrical energy, distribution networks, the world's electricity companies, including PLN, continue to build networks to remote areas. The network expansion must always be accompanied by a management system in maintaining the quality and quantity of supply, especially related to standard of Power Quality [1]. In a modern power grid system, consumers in the distribution network are very concerned about power quality (PQ) issues. In fact, they are prepared to pay a higher price for a reliable and good quality power supply [2]. On the other hand, some utility operators only focus on maintaining reliability, but ignore the quality of voltage and current. In addition, losses are an important indicator of the economic level of efficiency and power supply management. To improve the method of calculating losses on the line, real-time calculations are used as a method to be applied in calculating distribution channel losses caused by dynamic imbalance of three-phase loads [3]. Based on the algorithm built, the hardware system has the function to identify the unbalanced phase and can calculate the line loss on line. One way to improve the quality of electric power is to improve the load imbalance in a three-phase system, in order to improve service quality and reliability [4].

The distribution network is the main component in the distribution of electric power from substations that need to be monitored for loading. As one of the important assets in the power distribution system, efforts are needed to maintain transformer abnormal conditions using a distribution transformer operation management system. Effective transformer management has the goal of obtaining optimal load balance conditions with economics, for example, operating costs and loss costs. Operating conditions on transformers such as overload, over voltage and unbalanced load have a significant impact on maintenance and efficiency in the electricity supply industry. Abnormal conditions that occur in transformers can be prevented through real time monitoring so that there are periodic maintenance efforts at certain times. Unbalanced loading, especially in certain areas which are difficult to monitor at any time, is one of the factors affecting the decrease in transformer efficiency. Therefore, it is important to monitor so that proper maintenance can be carried out on transformers that supply a three-phase system to ensure the reliability and availability of electricity supply as a whole [5].

2. LITERATURE STUDY

The Condition-Monitoring (CM) method has been applied in the problem of monitoring transformer operating conditions by detecting the causes of failure. This system approach is able to reduce maintenance costs and can maintain the reliability and availability of existing services [6]. Currently information technology has a big role in human activities. Another way has been proposed using GSM (Global System for Mobile communication) via SMS, with relevant data analysis, it can be obtained automatically through the remote monitoring system [7] of the transformer temperature parameters. Remote monitoring system status is introduced with the combined composition of IoT system based system hardware and software [8]. Based on this, the functions and characteristics of each software module and database design are also introduced. The system improves the performance and stability of the power supply and reduces the time of power outages, can foresee possible faults through data analysis.

The application of Internet of Things (IoT) technology has begun to be used to implement monitoring of transformer health conditions in real time [9]. The IoT system itself is a telecommunications system with wireless media consisting of several mobile devices, sensors or other devices that communicate with each other and achieve certain goals [10]. This technology is used to obtain data and communicate with other devices via the internet network (wifi). Data originating from sensors is then processed and can then become useful information for decision makers. Furthermore, an online monitoring system and early warning system (EWS) were developed to detect failure earlier on transformers, then data is sent periodically from each transformer and further analyzed in decision making in the transformer management process [11]. The application of Internet of Things technology can effectively enhance the intelligence and network of computer monitoring systems.

In order to accurately diagnose the types of power transformer faults, proposals [12] and [13] propose a transformer fault diagnosis method based on a combination of time-shift multiscale bubble entropy and stochastic network configurations. First, entropy bubbles were introduced to overcome the drawbacks of traditional entropy models which depend too much on hyperparameters. Measurement of electrical energy parameters is carried out using the Matlab software, where current and voltage are based on direct measurements made using Matlab technology. While the research proposed in [14] is a new method for estimating the amount of copper losses using a fuzzy system, namely the first order Takagi-Sugeno-Kang (TSK) method combined with Singular Value Decomposition (SVD). The level of phase current unbalance is quite high and causes a significant three-phase power supply system voltage imbalance. The indicator calculation displays the characteristics of the voltage unbalance based on measurements processed using a computer program [4].

Another propose that has been made through the development of mobile embedded systems, is to monitor and record distribution transformer parameters such as current, temperature, oil level, vibration and humidity of the transformer. While in other proposals, it uses the detection of power distribution network imbalances using negative sequence parameters [15]. If an abnormality occurs, the system sends an alert message to the mobile phone as well as the monitoring unit containing information about the abnormality and some predefined instructions programmed in the micro controller [16]. Artiyasa [17], developed a smart home using the Blynk flat form on the Android system to control the Arduino module, where this application has features that make it easy for users to use it.

This proposal introduces the basic technology of Internet of Things technology and analyzes the main points of Internet of Things-based computer monitoring technology at this stage and then takes computer monitoring systems as research objects, and then analyzes computer monitoring systems based on Internet of Things technology to help related personnel better apply IoT technology to computer pad monitoring systems [8].

From the literature search, many studies have been conducted to monitor the three-phase loading conditions in the distribution system but have not provided an early warning to reduce losses in the system. In this study, we will monitor and provide early warning through an alarm indicator for neutral current loading conditions on a 3-phase system to determine the economic impact in real time on an IoT-based distribution system.

3. PROPOSED METHOD

The IoT system built in this study consists of an embedded system that functions to measure transformer parameters such as voltage, current and imbalance and perform calculations for power losses due to neutral currents. Because the distribution transformer life time needs to be monitored in real time, it is a major factor in maintaining service to customers. This of course also affects the income of electricity supply companies.



Figure 1. Sytem architecture for monitoring

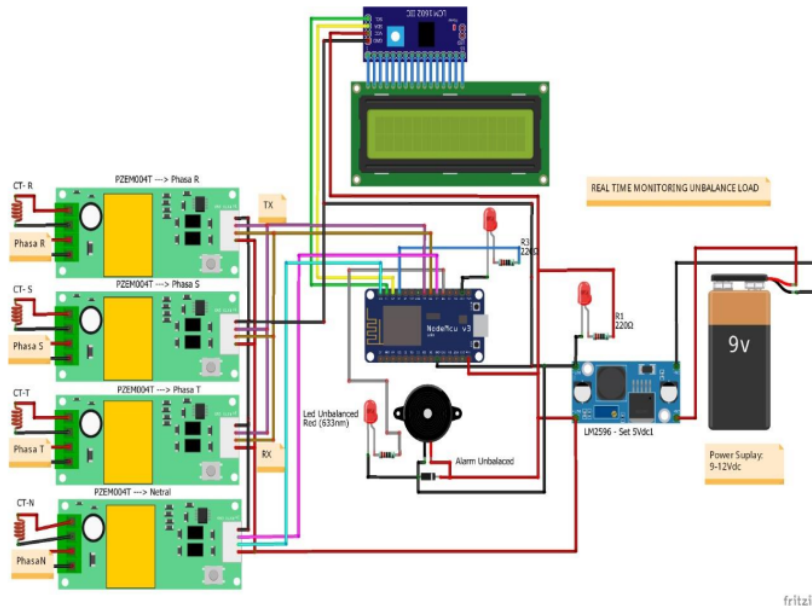

Figure 2 Diagram of real time the current unbalance monitoring with Arduino-based

List components:

1. IoT Micro-controller : ESP8266 -Node MCU V3
2. LCD 20x4 (I2C)
3. Current Sensor : PZEM-004T / 100A
4. Voltage Converter :LM-2596
5. Buzzer (indicator remote)
6. Led (indicator local unbalance load)
7. Power supply 9 V DC.
8. Resistor

Algorithm for monitoring:

1. Each PZEM sensor is connected to each RST phase on each CT (Current Transformer) including the neutral wire then the data read on each PZEM-004T sensor for current parameters is processed on ESP32.
2. Then ESP32 will send the data to the database which is already integrated with the website that we created earlier,
3. On the database side, the data that has been received from ESP32 will be adjusted to the data conversion table that has been prepared,
4. The ESP8266-NodeMcu-v3 module as a microcontroller and the Blynk android application as a monitoring and controlling tool for alarms.
5. After the data is received by the database, the website will display the data in a better visual,
6. Meanwhile, on the hardware side, when ESP32 has obtained data from the PZEM-004T sensor, it will display data in the form of data on the LCD.
7. The application platform uses Blynk Blynk which is compatible as a platform for IOS or ANDROID which is used to control Arduino modules, Rasbery Pi, Wemos and similar modules via the internet.
8. Arduino as a physical computing platform used is an interactive physical system with the use of software and hardware that can detect and respond to sensor parameters according to the data obtained.

Figure 2 is a monitoring circuit diagram that shows the process of controlling the monitoring tool. It starts when the sensor first starts sending the required data and then forwarding it to RS485 which functions as a means of communication/sending data to the ESP32 microcontroller. Furthermore, this ESP32 device functions as a data processor and plays an important role in the process of sending data to the database. So the important thing for ESP32 is that it can be connected to wifi or the internet so that it can send data that has been obtained on the sensor to the database, if it is not connected then do the interface synchronization until it can be connected. The user opens the website that has been created to send orders so that he can view the data already contained in the database. And on the hardware side, in order to be able to see the information that has been obtained from the PZEM-004T sensor which has been processed on the ESP32, it can be seen on the LCD with a size of 20x4. After getting the required data then we analyze whether the data obtained is correct. Besides measurements using sensors, the master node will perform calculations on several parameters which will later be sent to the server.

4. RESULT AND DISCUSSION

4.1. RESULT

The results of system trials on measuring the two transformers can be seen in Tables 4. The Arduino-based Blynk Cloud application displays data obtained from the sensors in graphical form. The graphical display on the android display can be used as trending information on the current of each phase in a transformer and obtain the maximum or minimum loading profile within a certain time range.

4.1.1. Result for no load

Table 1. Current measurement

Load Phasa	Measurement Direct measurement	Unbalance percentage			Remark
		With Monitoring based IoT	Direct measurement	With Monitoring based IoT	
Phasa R	0	0,00	0	0	similar
Phasa S	0	0,00	0	0	similar
Phasa T	0	0,00	0	0	similar

Table 2. Voltage measure

Load Phasa	Result measure Direct measurement	With Monitoring based IoT	Unbalance procentage		Remark
			Direct measurement	With Monitoring based IoT	
Phasa R	220	222.4	223.3	223,3	Under 20%
Phasa S	220	222.5	223.5	223,5	Under 20%
Phasa T	220	222.2	222,5	222,5	Under 20%

4.1.2. Result (balance)

Table 3. Current measurement for load balance

Load each phase Phasa	Result of measure Direct measurement	System testing		remark
		With Monitoring based IoT (Remote)	Direct measurement (local)	
Phasa R=25 W	0,1 Amp	0,11 Amp	0,11 Amp	under 20%
Phasa S=20 W	0,09 Amp	0,10 Amp	0,09 Amp	under 20%
Phasa T=15 W	0,07 Amp	0,08 Amp	0,08 Amp	under 20 %
Phasa Netral	0,02 Amp	0,03 Amp	0,03 Amp	under 20%

4.1.3. Load Test Results (Unbalanced)

Table 4. Current measurement for unbalance load

Load Phasa	Result of measure Direct measurement	Result of testing		Remark
		With Monitoring based IoT (Remote)	Direct measurement (local)	
Phasa R=25 Watt	0,1 Amp	0,11 Amp	0,11 Amp	under 20%
Phasa S=20 Watt	0,09 Amp	0,10 Amp	0,09 Amp	under 20%
Phasa T=10 Watt	0,03 Amp	0,03 Amp	0,03 Amp	under 20%
Phasa Netral	0,08 Amp	0,06 Amp	0,06 Amp	Over of setting unbalance to 20%

4.2 Early Warning System Testing

This testing using a setting as the tolerance limit of 20%, when the load is unbalanced where the neutral current is greater than the phase current, the local indicator light will light up and the Android system will give a notification as indicator to detect unbalanced load, for normal is green and up normal is red indicator.

Table 5. Early Warning System Performance

Load unbalance (scenario) % unbalance	Analytic	Result of testing		Early detection by notification on android system	
		(Local)	IoT Monitoring (Remote)	Indicator local (LED)	Notification on android
In=0 A	0	0	0	Off	Green
In=0,5	5 %	5,2 %	5,2 %	Off	Green
In=10 A	10%	10,6%	10,6%	Off	Green
In= 20 A	20%	20,3 %	20,3 %	on	Red (over 20%)

4.2. DISCUSSION

Based on the test results of the current sensor using a smartphone, satisfactory results were obtained in measuring the current imbalance in each phase. The performance of Arduino to monitor unbalanced load currents shows satisfactory results because the tolerance value between the results of direct measurements and monitoring in real time through the website will produce relatively the same values. If the load unbalance also gets bigger, the neutral current also increases so that the power loss on the line increases. The Blynk application requires internet devices (modem, wifi and internet access availability to be able to send notifications if an imbalance is detected by the current sensor with a signal or alarm. Based on testing, the time needed to send and receive notifications on the user's smartphone via the blynk application ranges from 3-4 seconds. This really depends on each internet service provider. With a load simulation set a tolerance limit of 20%, then when the load is very unbalanced where the neutral current is greater than the phase current then the local indicator light will turns on (on) while on the android system it will give an unbalanced load indicator (red color). This tolerance limit can be made according to the conditions of each power provider to prevent unbalanced operation of distribution system and reduce losses in the neutral conductor.

5 CONCLUSION AND RECOMMENDATION

The performance of Arduino to monitor unbalanced load currents shows satisfactory results because the tolerance value between the results of direct measurements and monitoring in real time through the website produces relatively the same values. The greater the three-phase load unbalance, the greater the magnitude of the neutral current to. This will cause greater power losses in the channel. By setting a tolerance limit of 20%, when the load is unbalanced where the neutral current is greater than the phase current, the local indicator light will light up and the Android system will give an unbalanced load indicator (red). This tolerance limit can be made according to the conditions of each power provider to prevent unbalanced operation of distribution transformers and reduce losses in the neutral conductor. Based on the test results during the research, this research obtained several things or recommendation. This test can be developed using real loads on electricity customers including the influence of the customer's power factor

6 ACKNOWLEDGMENTS

The researches thank to all parties who have supported this research activity, especially to the Chancellor of UMI together with the head of LP2S UMI who financed research activities through the Faculty's Excellence Research Grants in 2022. In addition, also to alumni and students who were involved during the design and testing our tool on behalf of the research team thank you very much.

REFERENCES

- [1] Musthofa, Ujang Rahman. View of Sistem Monitoring Online Real Time Beban Unbalance dan Overload Trafo Distribusi di PT PLN (Persero).pdf. Energi dan kelistrikan; 2020.
- [2] Balwani MR, Thirumala K, Mohan V, Bu S, Thomas MS. Development of a Smart Meter for Power Quality-Based Tariff Implementation in a Smart Grid. *Energies*. 2021 Sep 27;14(19):6171.
- [3] Meifang W, Min L, Junyi L, Wenlong P, Xixiu W. Research on the Monitoring System Design for the Line Loss of the Distribution Line Based on Dynamic Three-phase Unbalance Degree. *Procedia Comput Sci*. 2019;155:815-21.
- [4] Naumov I, Podyachikh S, Ivanov D, Tretyakov A, Bastron A. Analysis of unbalanced load low-voltage electrical networks operating modes. Nazarov AD, editor. *E3S Web Conf*. 2021;295:02005.
- [5] de Pablo A, Ferguson W, Mudryk A, Golovan D. On-line condition monitoring of power transformers: A case history. In: 2011 Electrical Insulation Conference (EIC) [Internet]. Annapolis, MD, USA: IEEE; 2011 [cited 2022 Dec 27]. p. 285-8. Available from: <http://ieeexplore.ieee.org/document/5996163/>

- [6] Abu-Elanien AEB, Salama MMA. Asset management techniques for transformers. *Electr Power Syst Res*. 2010 Apr;80(4):456–64.
- [7] Xiao-hui Cheng, Yang Wang. The remote monitoring system of transformer fault based on The internet of Things. In: *Proceedings of 2011 International Conference on Computer Science and Network Technology [Internet]*. Harbin, China: IEEE; 2011 [cited 2022 Dec 27]. p. 84–7. Available from: <http://ieeexplore.ieee.org/document/6181914/>
- [8] Qin Zhou, ZhengCai Fu. Research and implement of cost-effective remote transformer monitor system. In: *2012 International Conference on High Voltage Engineering and Application [Internet]*. Shanghai, China: IEEE; 2012 [cited 2022 Dec 27]. p. 410–2. Available from: <http://ieeexplore.ieee.org/document/6357137/>
- [9] Hanafi D, Aziz Z. Health Monitoring System for Transformer by using Internet of Things (IoT). *Int J Electr Energy Power Syst Eng*. 2022 Feb 28;5(1):19–23.
- [10] Atzori L, Iera A, Morabito G. The Internet of Things: A survey. *Comput Netw*. 2010 Oct;54(15):2787–805.
- [11] Budi Eko Prasetyo B, Widhy Hayuhardhika Nugraha Putra W. SISTEM MONITORING TRAFODISTRIBUSI PT. PLN(Persero) BERBASIS IoT. *J Teknol Inf Dan Ilmu Komput JTIK*. 2020 Desember;7(1):205–10.
- [12] Zhang P, Feng Q, Chen R, Wang D, Ren L. Classification and Identification of Power Quality in Distribution Network. In: *2020 5th International Conference on Power and Renewable Energy (ICPRE) [Internet]*. Shanghai, China: IEEE; 2020 [cited 2022 Dec 21]. p. 533–7. Available from: <https://ieeexplore.ieee.org/document/9233147/>
- [13] Chen F, Tian W, Zhang L, Li J, Ding C, Chen D, et al. Fault Diagnosis of Power Transformer Based on Time-Shift Multiscale Bubble Entropy and Stochastic Configuration Network. *Entropy*. 2022 Aug 16;24(8):1135.
- [14] Abadi AM, Sukisno T, Hano WPK. Determination of Copper Losses for Substation Transformers in Special Region of Yogyakarta using the Fuzzy System. 2022;
- [15] Dadashzade A, Aminifar F, Davarpanah M. Unbalanced Source Detection in Power Distribution Networks by Negative Sequence Apparent Powers. *IEEE Trans Power Deliv*. 2021 Feb;36(1):481–3.
- [16] Pawar RR, Deosarkar SB. Health condition monitoring system for distribution transformer using Internet of Things (IoT). In: *2017 International Conference on Computing Methodologies and Communication (ICCMC) [Internet]*. Erode: IEEE; 2017 [cited 2022 Dec 27]. p. 117–22. Available from: <http://ieeexplore.ieee.org/document/8282650/>
- [17] Artiyasa M, Nita Rostini A, Edwinanto, Anggy Pradifita Junfithrana. APLIKASI SMART HOME NODE MCU IOT UNTUK BLYNK. *J ReKayasa Teknol Nusa Putra*. 2021 Mar 2;7(1):1–7.
- [18] Zhao Z, Hu Q. The Application of a Computer Monitoring System Using IoT Technology. Bhardwaj A, editor. *Comput Intell Neurosci*. 2022 Jun 6;2022:1–11.

BIOGRAPHIES OF AUTHORS

Syarifuddin Nojeng was graduate as PhD Degree in Electrical Engineering from Universiti Teknologi Malaysia. He is currently associate Professor of Electrical Engineering at the Universitas Muslim Indonesian Makassar. He also a research has been funded by the Dikti and UMI fund. He has been elected on the keynote speaker for the several international conference. In addition, He is a reviewer for leading international journals such as IET, IJEPES, Telkomnika and IJEEIC. He can be contacted at email: syarifuddin.nojeng@umi.ac.id

Arif jaya received a Bachelor of Engineering Degree From the Department of Electrical Engineering from the University Moslem Indonesia Makassar in 2006, While the Master of Engineering Degree and PhD degree from the Department of Electrical Power Engineering, Gajah Mada University, in 2008 and 2012 respectively. He is currently senior lecture of Electrical Engineering at the Universitas Muslim Indonesian Makassar. He also a research has been funded by the Dikti and UMI fund. He can be contacted at email: arifjaya@umi.ac.id

Reny Murniati, received a Bachelor of Engineering Degree From the Department of Electrical Engineering from the Sawerigading University Makassar in 2006, While the Master of Engineering Degree from the Department of Electrical Power Engineering, Hasanuddin University, Makassar, in 2008. She is Senior Lecture, Faculty of Engineering, Sawerigading University, Makassar - Indonesia. Researching about being in Power System Operation and Control, Power Distributed Energy and Renewable Energy. She can be contacted at email: renymutmioati50@gmail.com

The Real Time Monitoring System and Early Detection of Unbalanced Load for the Three Phase Distribution Systems in Urban Areas

ORIGINALITY REPORT

14%

SIMILARITY INDEX

12%

INTERNET SOURCES

11%

PUBLICATIONS

%

STUDENT PAPERS

PRIMARY SOURCES

1	www.ncbi.nlm.nih.gov Internet Source	3%
2	www.mdpi.com Internet Source	2%
3	www.idexlab.com Internet Source	1%
4	olddrji.lbp.world Internet Source	1%
5	Meifang Wei, Jing Yang, Xuhua Zeng, Haiyan Wu, Di Huang. "Research on the Device Design for Calculation Distribution Line Loss Based on Dynamic Three-phase Unbalance Degree", E3S Web of Conferences, 2019 Publication	1%
6	ieeegsm-gpsprojects.blogspot.com Internet Source	1%
7	www.researchgate.net Internet Source	1%

8	lamintang.org Internet Source	1 %
9	doaj.org Internet Source	1 %
10	Michel Goossens, Michèle Jouhet. "Les commandes graphiques en LaTeX2e", Cahiers GUTenberg, 1995 Publication	<1 %
11	"Experimental Performance of Turbine Reaction Flow Type Straight with Blade Ratio Variation", International Journal of Innovative Technology and Exploring Engineering, 2020 Publication	<1 %
12	jtiik.ub.ac.id Internet Source	<1 %
13	www.ijsr.net Internet Source	<1 %
14	ijies.net Internet Source	<1 %
15	journals.pan.pl Internet Source	<1 %
16	Lieping Zhang. "Application of Comprehensive Correlation Degree Analysis in Power Transformer Fault Diagnosis", 2009 Second International Conference on Intelligent	<1 %

Computation Technology and Automation, 10/2009

Publication

17

helda.helsinki.fi

Internet Source

<1 %

18

"Advances in Smart System Technologies",
Springer Science and Business Media LLC,
2021

Publication

<1 %

19

Mayurkumar Rajkumar Balwani, Karthik
Thirumala, Vivek Mohan, Siqi Bu, Mini Shaji
Thomas. "Development of a Smart Meter for
Power Quality-Based Tariff Implementation in
a Smart Grid", Energies, 2021

Publication

<1 %

20

Ali Asghar Memon, Aneel Kumar, Ghan Sham,
Urooj Yasir. "Automated Protection of Power
Transformers at Distribution Grid Connected
to Green Energy Sources", 2018 IEEE
Canadian Conference on Electrical &
Computer Engineering (CCECE), 2018

Publication

<1 %

Exclude quotes On

Exclude matches Off

Exclude bibliography On