

# Implementation of an IoT-Based Control and Monitoring System for Neon Box Conditions in the Electrical Engineering Building

## Hikmatul Amri

Politeknik Negeri Bengkalis  
Jurusan Teknik Elektro  
Jl. Bathin Alam, 28714,  
Bengkalis, Riau, Indonesia  
[hikmatul\\_amri@polbeng.ac.id](mailto:hikmatul_amri@polbeng.ac.id)

## Ilham Haris

Politeknik Negeri Bengkalis  
Jurusan Teknik Elektro  
Jl. Bathin Alam, 28714,  
Bengkalis, Riau, Indonesia  
[ilhamharis002@gmail.com](mailto:ilhamharis002@gmail.com)

## Riski Kurniansyah

Politeknik Negeri Bengkalis  
Jurusan Teknik Elektro  
Jl. Bathin Alam, 28714,  
Bengkalis, Riau, Indonesia  
[ilhamharis002@gmail.com](mailto:ilhamharis002@gmail.com)

## Hardi B

Politeknik Negeri Bengkalis  
Jurusan Teknik Elektro  
Jl. Bathin Alam, 28714,  
Bengkalis, Riau, Indonesia  
[hardi@polbeng.ac.id](mailto:hardi@polbeng.ac.id)

## Stephan

Politeknik Negeri Bengkalis  
Jurusan Teknik Elektro  
Jl. Bathin Alam, 28714,  
Bengkalis, Riau, Indonesia  
[stephan@polbeng.ac.id](mailto:stephan@polbeng.ac.id)

## Jefri Lianda

Politeknik Negeri Bengkalis  
Jurusan Teknik Elektro  
Jl. Bathin Alam, 28714,  
Bengkalis, Riau, Indonesia  
[stephan@polbeng.ac.id](mailto:stephan@polbeng.ac.id)

## Zulkifli

Politeknik Negeri Bengkalis  
Jurusan Teknik Elektro  
Jl. Bathin Alam, 28714,  
Bengkalis, Riau, Indonesia  
[zulkifli@polbeng.ac.id](mailto:zulkifli@polbeng.ac.id)

## Azzahra Zulaika

Politeknik Negeri Bengkalis  
Jurusan Teknik Elektro  
Jl. Bathin Alam, 28714,  
Bengkalis, Riau, Indonesia  
[zahracaniago1212@gmail.com](mailto:zahracaniago1212@gmail.com)

## Marzuarman Marzuarman

Politeknik Negeri Bengkalis  
Jurusan Teknik Elektro  
Jl. Bathin Alam, 28714,  
Bengkalis, Riau, Indonesia  
[zahracaniago1212@gmail.com](mailto:zahracaniago1212@gmail.com)

Article history: Received October 12, 2025 | Revised December 29, 2025 | Accepted January 16, 2026

**Abstract** – The implementation of an Internet of Things (IoT)-based control and monitoring system for the neon box at the Electrical Engineering Department Building aims not only to improve operational efficiency and installation safety, but also to contribute to the development of intelligent outdoor lighting management systems in academic environments. As an information medium and building identity, the neon box requires continuous and reliable real-time monitoring of electrical and optical parameters to minimize maintenance delays and prevent unexpected failures. In this study, an integrated IoT-based system was designed and implemented using a NodeMCU ESP8266 microcontroller as the main controller, a PZEM-004T sensor for voltage, current, power, and energy measurement, a TSL2561 lux sensor for light intensity detection, and a relay module as an actuator for remote lamp control. The Blynk IoT platform serves as a cloud-based interface for real-time data visualization and remote operation via a smartphone. The proposed system enables periodic data transmission and provides comprehensive monitoring information through a digital dashboard, allowing operators to evaluate neon box performance anytime and anywhere. The main scientific contribution of this research lies in the validation of a low-cost, scalable, and reliable IoT architecture for outdoor electrical signage monitoring, supported by quantitative sensor accuracy analysis and real-time system responsiveness evaluation. Experimental results show that the PZEM-004T sensor achieves an average measurement error of 0.66% for voltage and 2.53% for current, while the TSL2561 sensor records an average

error of 1.42%, indicating sufficient accuracy for practical monitoring applications. Furthermore, the system demonstrates the capability to detect lamp failure conditions based on combined voltage and power parameters, with an average response time of 0.856 seconds on the Blynk IoT application, which is influenced by internet network quality. Overall, this research contributes to the advancement of smart campus infrastructure by providing a practical reference model for implementing IoT-based control and monitoring systems for outdoor lighting and signage, with potential scalability for broader smart building and energy management applications.

**Keywords:** Control, Monitoring, Maintenance, Sensor.



Creative Commons Attribution-NonCommercial-ShareAlike 4.0 International License.

## I. INTRODUCTION

Neon boxes are a form of lighting and visual identity commonly used on institutional buildings, including the Electrical Engineering Department Building. The presence of a neon box serves as an information marker while also strengthening the institution's image, requiring the device to operate properly and consistently. However, in practice, maintaining neon boxes is often constrained by the lack of monitoring and control systems, which are still conducted manually. The absence of information

regarding voltage, current, power, and operational status may lead to risks such as equipment damage, energy waste, and electrical safety hazards [1], [2].

With the advancement of Internet of Things (IoT) technology, the monitoring and control of electrical devices can now be performed in real time and remotely [3]–[5]. This technology enables each device to be connected to the internet so that operational condition data can be automatically transmitted to users through digital platforms [6]. Implementing IoT in lighting systems such as neon boxes has become highly relevant to improving operational efficiency, monitoring accuracy, and maintenance effectiveness [7], [8].

In this study, a control and monitoring system for the neon box at the Electrical Engineering Department Building is designed using a NodeMCU ESP8266 microcontroller, electrical sensors (voltage and power), a lux sensor for measuring ambient light intensity, and a relay module for both automated and manual control of the neon box lighting. The ESP8266 is widely used due to its low power consumption, Wi-Fi capability, and ease of integration into IoT applications [9]–[11]. Electrical and light sensors when selected with good accuracy enable real-time monitoring of critical parameters in lighting systems [12], [13].

All data are displayed through the Blynk IoT application, allowing users to monitor and control the system anytime via smartphone [14], [15]. Blynk are widely used in IoT research because of their ease of integration, flexible user interface, and real-time monitoring and control capabilities [16], [17]. With this system, the management of the neon box is expected to become more efficient, safer, and more integrated in accordance with the current development of IoT technology [18], [19].

Sumendap and colleagues designed a remote-control system for neon box lamps using an Android smartphone as a solution to the limitations of conventional control systems with limited range. With technological advancements, the control of electronic devices can now be performed more flexibly using wireless connections such as Bluetooth. The system was designed to turn the neon box lamp on and off through text commands "ON" and "OFF" sent from an Android application. Test results showed that the Bluetooth module functioned effectively up to 20 meters without obstacles and up to 15 meters with obstructions [20].

Rahmad and colleagues developed a prototype lamp control system, preceded by observations regarding the need for such a prototype. This system uses the Blynk application as a lamp controller connected to the internet via a WiFi network. From tests conducted 30 times to measure the connection time between the Blynk application on the smartphone and the ESP-01 module, the average connection time obtained was 11.61 seconds. In addition, the system was tested at different times of day (morning,

afternoon, evening, night) using two different networks: IndiHome and Indosat, resulting in an average response time to process commands (ON/OFF) of 0.28 seconds [21].

Safitri's research developed a prototype system to control five LED lamps based on Arduino, managed through a website. The system operates by sending on-off commands from the website to the server, then forwarding them to the Arduino, and sending the LED status back to the server for display. Black-box testing showed excellent results, with 21 successful software tests and 5 successful hardware tests without failures. The system was found to be effective in providing control and monitoring capabilities while reducing energy waste [22].

Adam and colleagues developed an IoT-based monitoring system for street lighting (PJU) using a ZMPT101B sensor for voltage, an ACS712 sensor for current, and an ESP8266-01 WiFi module connected to an Arduino Mega2560. Data were sent to the ThingSpeak platform and could be accessed via mobile phones or laptops. Testing showed a voltage sensor accuracy of 96.7%, with graphical displays and indicators. The system effectively monitored the condition of street lights and has the potential to be developed into an efficient smart system compliant with SNI standards [23].

Based on the analysis of previous studies, it can be observed that most existing systems focus either on remote control or basic monitoring, with limited integration of electrical parameter analysis, ambient light sensing, and automatic operational decision-making within a single platform. Therefore, this research aims to design and implement an IoT-based neon box control and monitoring system that integrates real-time electrical parameter monitoring, ambient light-based automatic control using an LDR sensor, and remote operation via smartphone. The specific objectives of this study are: (1) to develop a wireless IoT-based system capable of monitoring voltage, power consumption, and light intensity of a neon box in real time; (2) to implement automatic and manual control of neon box lighting based on environmental light conditions and user commands; and (3) to evaluate the system's performance in terms of responsiveness and practical applicability when deployed at the Electrical Engineering Building of Politeknik Negeri Bengkalis.

## II. METHOD

In this study, there are generally two main designs: the hardware (electronics and wiring) and the software. On the hardware side, the microcontroller system is powered by a 5V mini UPS. The PZEM-004T sensor is used to measure current, voltage, and electrical power consumption, and is connected to the NodeMCU through four wires (Vcc, GND, Rx, and Tx). The TSL2561 sensor is used to measure the light intensity produced by the neon box lamp and is

connected through four wires (Vcc, GND, SCL, and SDA). A relay module is used to control the neon box lamp with three pin configurations (Vcc, GND, and DO/digital output). The NodeMCU 8266 microcontroller functions to read sensor inputs, process incoming data, and control the neon box lamp. In addition, Wi-Fi/internet connectivity is required to send sensor data to the user's smartphone and to manually control the lamp via the smartphone. The complete system wiring diagram can be seen in Figure 1.

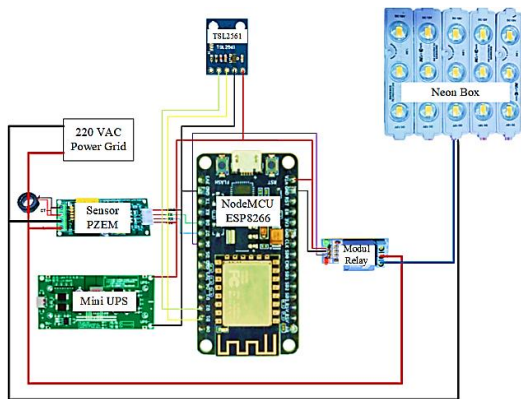

Figure 1. Full System Wiring Diagram

On the software side, the control and monitoring dashboard is designed using Blynk IoT. Several monitoring panels are provided, including voltage, power, and light intensity. The control panel includes a virtual button used to turn the neon box lamp on and off, and the status panel displays the real-time condition of the neon box lamp. The design of the Blynk IoT dashboard panels used in this system is shown in Figure 2.



Figure 2. Control and monitoring design on Blynk IoT

Although the hardware and software designs are described clearly and are easy to follow, the research methods presented in this study are primarily focused on system implementation. The methodology lacks deeper methodological rigor, particularly in terms of experimental design, statistical validation of sensor accuracy, and justification of the selected components and system architecture. Performance evaluation is mainly descriptive and operational, without

comprehensive quantitative analysis or comparative testing against alternative designs. Future work is expected to incorporate structured experimental procedures, statistical analysis, and design justification to strengthen the scientific contribution of the proposed system.

In detail, the overall working system of the device developed is illustrated in the flowchart shown in Figure 3.

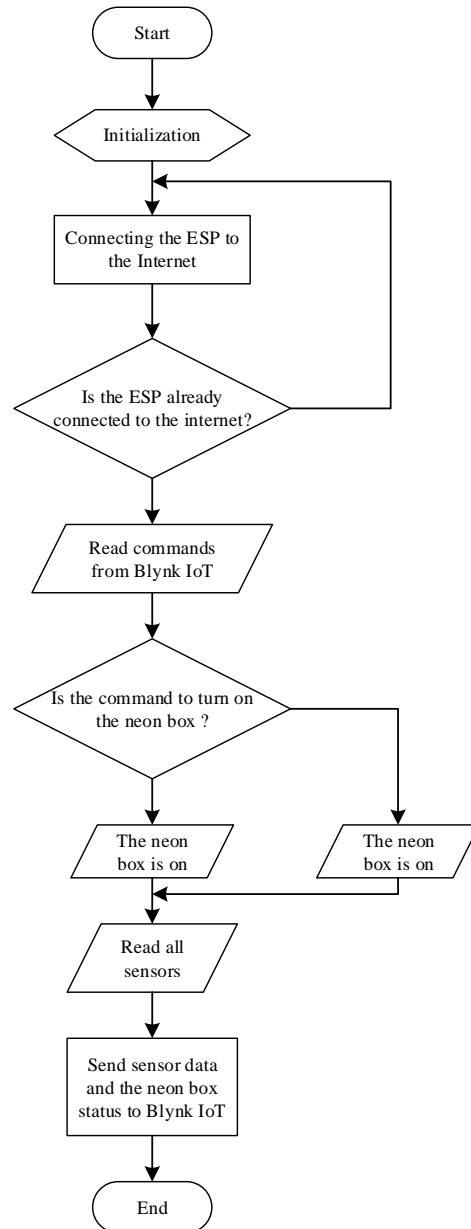

Figure 3. Flowchart of the device operation

Based on Figure 3, it can be briefly explained that the system begins with the initialization of all input and output components, followed by connecting the ESP8266 to the internet. Once connected, the Blynk IoT dashboard becomes active and can be used to control the neon box and monitor voltage, power, light intensity, and the status of the neon box. In this system, the condition of the neon box is categorized into three

states: Normal, Not Turning On, and Faulty, with all data updated every second.

Although this research procedure is clearly described and supported by the flowchart, it primarily represents the operational workflow of the system. The procedure focuses on system operation, data acquisition, and real-time monitoring, but does not explicitly include a structured experimental research workflow such as defined testing scenarios, controlled variables, repeated trials, or quantitative data analysis. As a result, the procedure lacks an explicit experimental framework for systematic performance evaluation and validation.

Consequently, the operational workflow described above serves as the basis for system implementation and real-time operation. The performance of the proposed system, including the accuracy of sensor readings, response time, reliability of data transmission, and effectiveness of the neon box status classification, is further evaluated and discussed in the Results and Discussion section based on experimental observations and system testing.

### III. RESULTS AND DISCUSSION

The hardware design consists of a combination of a mini UPS circuit that supplies voltage to the entire system. The mini UPS is equipped with a backup battery used as an emergency power source in the event of a 220VAC mains failure. The PZEM-004T sensor is used to measure the voltage and electrical power of the neon box lamp, while the TSL2561 sensor measures the light conditions around the neon box lamp area. A relay module is used to control the lamp when it is not in use, and the ESP8266 serves as the main controller responsible for reading all sensor inputs, controlling the neon box lamp load, and transmitting real-time data such as voltage, power, lumen, and device status to the monitoring and control dashboard on the Blynk IoT application. On Blynk IoT, the displayed data include Voltage, Power, Light Intensity/Lumen, and Device Status, along with a virtual button for remote control. The complete hardware design can be seen in Figure 4, while the Blynk IoT dashboard design is shown in Figure 5.

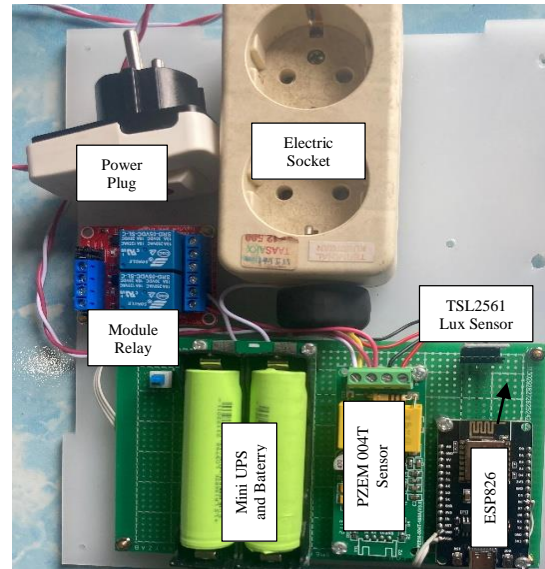

Figure 4. Hardware Design Results

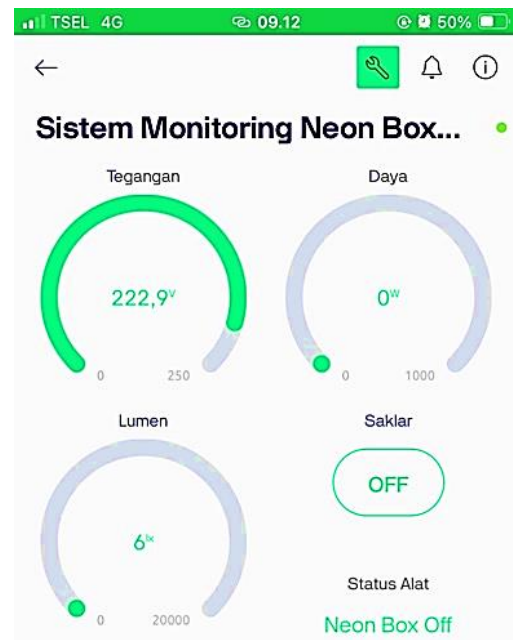

Figure 5. Software Design Results

#### A. PZEM-004T Voltage Sensor Testing

Initial testing of the AC voltage sensor using the PZEM-004T was carried out to determine the error rate in measuring varying AC voltage levels. The test was conducted with voltage variations ranging from 168 to 243 volts using an AC Voltage Regulator. The purpose of this test was to obtain the average error in voltage measurements between the sensor and the METREL MD9060 multimeter. The results of the voltage comparison test can be seen in Table 1.

Table 1. Comparison of AC Voltage Measurements

Voltage Sensor (V)	Voltmeter (V)	Error (%)
168,8	168,85	0,03
195,3	192,77	1,31
216,7	218,67	0,90
227,9	229,12	0,53
243,4	242,17	0,51
Average		0,66

The voltage measurement results obtained using the PZEM-004T sensor show an average error of 0.66 %, which indicates high measurement reliability across a wide voltage range (168–243 V). Compared to similar IoT-based electrical monitoring systems reported in previous studies, this error level is comparable or lower than typical low-cost AC voltage sensors, which often exhibit errors above 1 %. This result confirms that the PZEM-004T is suitable for real-time monitoring of neon box electrical conditions without requiring expensive instrumentation.

B. PZEM-004T Current Sensor Testing

The AC current sensor was tested to determine the error by comparing the sensor’s measurement results with those of the METREL MD9060 multimeter. The test was conducted five times using different electrical load levels. The test results of the sensor and the multimeter can be seen in Table 2.

Table 2. Comparison of AC Current Measurements

Current Sensor (A)	Amperemeter (A)	Error (%)
0,12	0,122	1,64
0,18	0,188	4,26
0,25	0,259	3,47
0,36	0,367	1,91
0,42	0,422	0,47
Average		2,35

The average current measurement error of 2.35 % is relatively higher than the voltage error, particularly at low current levels. This behavior aligns with theoretical characteristics of current sensing, where lower current magnitudes tend to produce higher relative errors due to sensor resolution and noise sensitivity. Similar trends have been reported in prior IoT lighting and energy monitoring studies, indicating that the observed error is a known limitation rather than a system flaw. Despite this limitation, the accuracy remains sufficient for detecting abnormal power consumption and lamp failure conditions.

C. TSL2561 Lumen Sensor Testing

The lumen sensor was tested to determine the error by comparing the sensor’s measurement results with those of the PeakTech 5035 lux meter. The test was conducted five times using lamp light with different power levels. The test results of the TSL2561 sensor and the lux meter can be seen in Table 3.

Table 3. Comparison of Lumen Measurements

Lux Sensor (lx)	Luxmeter (lx)	Error (%)
1547	1552	0,32
1469	1547	1,42
184	186	1,08
177	180	1,67
111	114	2,63
Average		1,42

The TSL2561 lux sensor achieved an average error of 1.42 %, demonstrating reliable performance for illumination monitoring. This level of accuracy supports its use not only for monitoring light intensity but also for detecting performance degradation or

lamp malfunction. Compared to previous lighting control systems that rely solely on on/off status without illumination feedback, the inclusion of lux measurement provides a more meaningful representation of lighting performance.

D. Relay Module Testing

The relay module was tested to determine the logic input voltage and the output terminal voltage produced when the virtual switch is activated and when the virtual switch is deactivated. The relay module test results can be seen in Table 4.

Table 4. Relay Module Testing

Virtual Switch	Input Logic (VDC)	Output Terminal (VAC)
<b>On</b>	3,2	223,9
<b>Off</b>	0	2,694

The relay module testing shows that a 3.2 VDC logic input successfully activates the relay, supplying 223.9 VAC to the load, while a 0 VDC input disconnects the lamp with only residual voltage (2.694 VAC). These results confirm reliable switching, effective isolation, and safe relay operation for IoT-based neon box control.

E. Overall System Testing

Overall testing was carried out to determine the system’s performance in terms of both control and monitoring, as well as to measure the response time within one control and monitoring cycle. The test was performed by applying on and off commands to the virtual switch on the Blynk IoT dashboard, then observing the monitoring display and the actual condition of the device. The results of this overall system testing can be seen in Table 5.

Table 5. Overall Testing

Virtual Switch	Voltage (V)	Power (W)	Condition	Respon (S)
<b>On</b>	220,7	57	<b>Normal</b>	0,899
<b>Off</b>	220,9	0	<b>Off</b>	0,912
<b>On</b>	222,3	0	<b>Broken</b>	0,758
Time Average				0,856

Beyond individual sensor performance, the key contribution of this system lies in its ability to interpret combined electrical and illumination data. The experimental results in Table 5 demonstrate that the system can distinguish between three operational states: normal operation, lamp-off condition, and lamp failure condition. Specifically, the presence of nominal voltage with zero power consumption enables the system to identify a broken lamp scenario, which cannot be detected through voltage monitoring alone.

The measured average response time of 0.856 seconds indicates that the system operates within near real-time constraints suitable for building-scale monitoring applications. While this response time is slower than purely local control systems, it is consistent with cloud-based IoT architectures where latency is influenced by network quality, server processing, and data synchronization intervals.

Compared to earlier IoT lighting systems that report response times ranging from sub-second to several seconds, the obtained response time demonstrates a balanced trade-off between functionality and responsiveness.

#### IV. CONCLUSION

Based on the results of sensor accuracy testing and overall system performance evaluation, it can be concluded that the Blynk IoT interface is capable of reliably displaying four key parameters—voltage, electrical power, light intensity (lumen), and the operational status of the neon box lamp at the Electrical Engineering Building. Data analysis shows that the PZEM-004T sensor achieves an average voltage measurement error of 0.66% and an average current measurement error of 2.53%, while the TSL2561 sensor records an average error of 1.42%, indicating sufficient accuracy for real-time monitoring applications. Furthermore, analysis of combined voltage and power data confirms the system's ability to identify abnormal operating conditions, such as lamp failure, with an average response time of 0.856 seconds on the Blynk IoT platform. The observed response time is consistent with cloud-based IoT system characteristics and is influenced by internet connectivity and network performance. This study is limited to testing the system on a single neon box installation, so the performance evaluation has not yet represented large-scale or multi-node implementations. In addition, system response time is influenced by internet network quality, which was not quantitatively analyzed under different bandwidth or latency conditions. Future research can focus on deploying the system across multiple neon boxes, integrating data logging and energy consumption analysis, and applying predictive maintenance algorithms to enhance fault detection accuracy and scalability.

#### V. ACKNOWLEDGMENTS

This research was carried out thanks to the support of the Bengkalis State Polytechnic.

#### REFERENCES

- [1] N. D. K, J. K. Gowda, H. S, H. S. T, and J. John, "Wi-fi Controlled Smart Home Automation," in *2022 IEEE International Conference on Data Science and Information System (ICDSIS)*, 2022, pp. 1–5. doi: 10.1109/ICDSIS55133.2022.9915976.
- [2] O. Ayan and B. Turkay, "IoT-Based Energy Efficiency in Smart Homes by Smart Lighting Solutions," in *2020 21st International Symposium on Electrical Apparatus & Technologies (SIELA)*, 2020, pp. 1–5. doi: 10.1109/SIELA49118.2020.9167065.
- [3] P. P. Ray, "A survey on Internet of Things architectures," *J. King Saud Univ. - Comput. Inf. Sci.*, vol. 30, no. 3, pp. 291–319, 2018, doi: <https://doi.org/10.1016/j.jksuci.2016.10.003>.
- [4] V. Sámano-Ortega, H. Méndez-Guzmán, J. Martínez-Nolasco, J. Padilla-Medina, M. Santoyo-Mora, and J. Zavala-Villalpando, "Electrical Energy Consumption Monitoring System in the Residential Sector using IoT," *IEEE Lat. Am. Trans.*, vol. 21, no. 1, pp. 158–166, 2023.
- [5] N. Wibowo, D. Mursyitah, H. Zarory, and A. Ullah, "Fire Detection Design Based on Gas Leakage Accompanied by Fire Location Point Using ESP32 Based on IoT," *PROtek J. Ilm. Tek. Elektro*, vol. 12, no. 1, pp. 60–66, 2025.
- [6] A. Mosenia and N. K. Jha, "A Comprehensive Study of Security of Internet-of-Things," *IEEE Trans. Emerg. Top. Comput.*, vol. 5, no. 4, pp. 586–602, 2017, doi: 10.1109/TETC.2016.2606384.
- [7] S. Godara and V. K. Srivastava, "An IoT-Based Smart Street Lighting System to Lower Energy Consumption," *J. Electr. Syst.*, vol. 19, no. 2, pp. 163–173, 2023.
- [8] Z. Chen, C. B. Sivaparthipan, and B. Muthu, "IoT based smart and intelligent smart city energy optimization," *Sustain. Energy Technol. Assessments*, vol. 49, p. 101724, 2022, doi: <https://doi.org/10.1016/j.seta.2021.101724>.
- [9] Y. S. Parihar, "Internet of Things and Nodemcu," *J. Emerg. Technol. Innov. Res.*, vol. 6, no. 6, pp. 1085–1088, 2019.
- [10] U. Singh and M. A. Ansari, "Smart Home Automation System Using Internet of Things," in *2019 2nd International Conference on Power Energy, Environment and Intelligent Control (PEEIC)*, 2019, pp. 144–149. doi: 10.1109/PEEIC47157.2019.8976842.
- [11] A. Akhriana, Husain, S. Aisa, S. R. Arifin, M. M. Nur, and H. Sulihin, "Parking Management System Prototype Using Multiplatform Based NodeMCU," *Protek J. Ilm. Tek. Elektro*, vol. 11, no. 3, pp. 188–194, 2024.
- [12] S. V, S. V, S. S, V. N, A. M, and D. D, "Illuminating the Future: A Smart Street Light Controlling and Monitoring System Using Internet of Things Enabled Smart Sensors," in *2024 Ninth International Conference on Science Technology Engineering and Mathematics (ICONSTEM)*, 2024, pp. 1–8. doi: 10.1109/ICONSTEM60960.2024.10568747.
- [13] U. Ali, M. U. Ramzan, W. Ali, M. E. Rana, and A. Qayyum, "IoT-Driven Smart Energy Monitoring: Real-time Insights and AI-Based Unit Predictions," in *2023 IEEE 21st Student Conference on Research and Development (SCORED)*, 2023, pp. 672–677. doi: 10.1109/SCORED60679.2023.10563825.
- [14] H. Amri, W. M. Faizal, B. Hardi, A. W. Wahyudi, A. Ardi, and L. Garcia, "The Public Street Lighting System Using Solar Panels Based on Global Positioning System (GPS) and Internet of Things," in *7th International Conference on Applied Science and Technology*, 2025, pp. 1–9.
- [15] H. Amri, Stephan, Zulkifli, Hardi, I. Haris, and A. Zulaika, "Voltage and Current Monitoring System of Neon Box Lamps at the Electrical Engineering Building," in *International Conference on Industrial Technology and Business*, 2025, pp. 186–192.
- [16] P. Sujidha, P. Radha, T. S. Priya, A. Usha, and M. S. Devi, "IOT Based Home Automation Using NodeMCU and Blynk Application," *Int. J. Mod. Trends Sci. Technol.*, vol. 7, no. 3, pp. 151–153, 2021.
- [17] V. Palaniappan, S. Poovalingam, P. V. Sampath, and K. Solaraj, "An Integrated IOT Enabled Smart Lighting Platform to Monitor and Control Distributed Devices," in *2023 IEEE Bombay Section Signature Conference (IBSSC)*, 2023, pp. 1–6. doi: 10.1109/IBSSC58994.2023.10170947.
- [18] F. Chekired *et al.*, "Design and Implementation of Control and Management System for Smart Street Lighting," in *2024 IEEE Sustainable Smart Lighting World Conference & Expo (LS24)*, 2024, pp. 1–4. doi: 10.1109/LS2463127.2024.10881773.
- [19] F. T. Nigel and O. M. Longe, "Smart Energy Efficient Lighting System for Smart Buildings," in *2021 IEEE PES/IAS PowerAfrica*, IEEE, 2021, pp. 1–5.
- [20] A. Sumendap, A. Tembo, and F. Manoppo, "Perancangan Lampu Neon Box Menggunakan Arduino Pada Universitas Pama Raya," *J. Log.*, vol. 10, no. 1, pp. 25–30, 2022.
- [21] M. P. Rahmad, Turahyo, and N. Imansyah, "Rancang Bangun Kendali Lampu Dengan Menggunakan Ponsel Pintar Android Via Wifi Berbasis Mikrokontroler," *J. ELKHA*, vol. 12, no. 1, pp. 41–46, 2020.
- [22] A. H. Safitra, "Prototipe Sistem Kontrol Lampu LED Melalui Jaringan Internet Berbasis Arduino," *J. List. Instrumentasi dan Elektron. Terap.*, vol. 2, no. 1, pp. 16–20, 2021.
- [23] A. Adam, M. Muharnis, A. Ariadi, and J. Lianda, "Penerapan IoT untuk Sistem Pemantauan Lampu Penerangan Jalan Umum," *Elinvo (Electronics, Informatics, Vocat. Educ.)*, vol. 5, no. 1, pp. 32–41, 2020, doi: 10.21831/elinvo.v5i1.31249.