

Effect of Pulse Width Modulation on Proportional, Integral, and Derivative Coefficient Characteristics

by Protek Unkhair

Submission date: 01-Jan-2023 07:32AM (UTC+0300)

Submission ID: 1906905953

File name: 5033-13267-1-SM.docx (248.55K)

Word count: 4569

Character count: 22463

Effect of Pulse Width Modulation on Proportional, Integral, and Derivative Coefficient Characteristics

Tonny Suhendra^{*a}, Rusfa^a, Sapta Nugraha^a, Harits Aditya Nugraha^a, Septia Refly^a

⁸ ^aElectrical Engineering
Universitas Maritim Raja Ali Haji
Jalan Politeknik Senggarang
Tanjungpinang, Indonesia
Corresponding: tonny@umrah.ac.id

Abstract – Based on the value of feedback obtained from the sensor (LDR), the PID algorithm uses the error value obtained from the comparison between the sensor value and the setpoint value to perform calculations so that the PWM generator will use the output value to produce a row of pulses that will be converted to a voltage (signal) with a range of 0 to 255 (0 volt to 5 volt) and is used to turn on the LED lamp according to the desired light level. The output characteristics generated by the PID control for each coefficient can be used as a benchmark to determine the correct coefficient value for Proportional coefficient, Integral coefficient and Derivative coefficient as a whole. From the test results, it can be seen that the coefficient value adjustment can be taken based on the size of the difference or error contained in the system. If the difference in error is slight, the use of large coefficient values, especially in derivative coefficients. It helps the system achieve a stable condition and reduces overshoot. Still, if the error value is significant, then applying a considerable efficiency value will make the system achieve stable condition stable becomes a little tricky because it is possible to overshoot the PID output.

Keywords: feed-back controller, PWM, PID coefficient, closed-loop system.



¹² Creative Commons Attribution-NonCommercial-ShareAlike 4.0 International License.

I. INTRODUCTION

A system can work well if it can be monitored and controlled directly anytime and anywhere. At first, monitoring (using eyes) and controlling were still carried out directly by the user. Currently, a system is equipped with various sensors and actuators so that the system can work independently, which is known as a control system. Basically, when working, the control system is divided into two, namely a control system that works in an open-loop and a control system that works in a closed loop that works based on a feedback system. These two systems are the basis of artificial intelligence techniques, in which later a system can make its own decisions [1].

Feedback information is very important in the control system, as was done by [2] in his research to see the possibility of the system failing to get feedback information by looking at the position (pole) of the sensor to get a feedback link. According to the structure

of a large-scale closed-loop system, the research carried out is to see the resilience of a system when the subject (system) is temporarily not connected to the feedback system. Pulse Width Modulation (PWM) is a feedback-based controller, which produces signals in the form of HIGH (ON) or LOW (OFF) pulses. Feedback is very important in the control system, especially in closed-loop control, [3] conducted a study to see the interaction between open-loop and closed-loop control in the MPC algorithm (predictive control model). A variable duty cycle rate can be generated by PWM and used to control the energy requirements (voltage) in a system.

MPC control is very suitable for both linear and non-linear systems and is currently widely used in various industrial fields [4]. The MPC algorithm is one of the algorithms that have a very simple working system, by measuring the current state system, optimizing the cost of control using a prediction-based response system, and then applying the first part of the calculation results (output control), then the process repeat.

PID control uses proportional, integral, and differential properties in controlling a system and is one type of control that focuses on linear process control [5]. This study will analyze the characteristics of the proportional coefficient, the characteristics of the integral coefficient, and the characteristics of the derivative coefficient, by utilizing PWM as a feedback signal generator that will be used to control the plant.

The PID algorithm will perform calculations to find the output value. Where the calculation results obtained from the PID algorithm will be converted within a certain range of values (voltage) using the PWM method (0-255). The PWM generator will send this value to the actuator (plant) so that the output value will approach the desired value (setpoint).

II. METHODS

Basically, the control system consists of two basic concepts, namely the open-loop control system and the closed-loop control system.



Figure 1. Open-loop Control System

Effect of Pulse Width Modulation on Proportional, Integral, and Derivative Coefficient Characteristics

The open-loop control system is shown in Figure 1 is used if it can be ascertained that the system works in a fixed environment and is free from significant disturbances. This is because the open-loop system does not have feedback in the system and cannot adjust the situation if the environment in which the system is placed is dynamic or always changing.

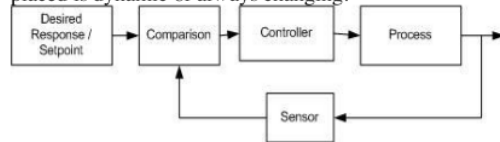

Figure 2. Closed-loop Control System

As stated by [6] where the designed system (UGV on agricultural land) cannot run well when the land contour is uneven or non-uniform where the UGV speed is always changing, and its movement is disrupted. To overcome this problem, a system that works based on a closed-loop system can be implemented, usually equipped with a measurement component (sensor) that will be used to read the output of the system known as feedback. Basically, feedback control is a control method that uses the value (information) of the results of measuring the output of a system (output). [7] There are two main types of feedback control systems, namely, positive feedback (increasing input) and negative feedback (decreasing input).

The application of the closed-loop control system is shown in Fig. 2, where there is an additional system (sensor) that will be used to read the output of a system, which will be compared with the setpoint value (desired response) that has been previously set by the user (user). According to [8], the difference in approach in closed-loop identification is obtained from the difference in the dynamics of the input-output parameters and the form of the existing disturbance. Figure 3 is a form of implementing a good feedback system, as presented by [8] regarding the approach in the control system.

- Direct approach: ignore feedback information and identify open-loop plants by measuring input $u(t)$ and output $y(t)$.
- Indirect approach: identify the closed-loop transfer function by measuring your reference signal $r(t)$ output $y(t)$ output and using estimates to reconstruct the open-loop model using the knowledge of the controller
- The joint input-output approach: identify the two transfer functions from $r(t)$ to $y(t)$ and $r(t)$ to $u(t)$ and use them to calculate the estimation of the open-loop model.

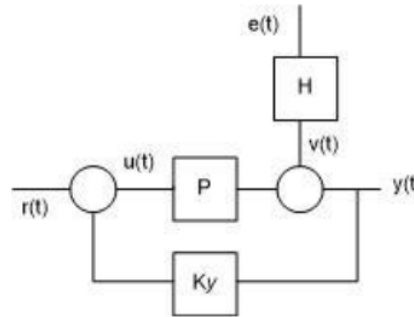

Figure 3. Feedback system based on Good System and Controller [8]

The development of control systems is currently also used in robotics technology. The camera as a sensor is used to retrieve information, as done by [9] in research to develop a robotic arm that is applied in rehabilitation. The camera is used to take information about the distance and position of objects used as system feedback. One of the methods used in feedback system-based control is the Pulse Width Modulation (PWM) method. [10] in his research used PWM feedback control as a regulation of the angular positioning of the manipulator robot. According to [11] in his research, PWM is a method that has been widely used for various control systems, such as robotics, industrial process control, power control systems, and so on. The PWM circuit converts the DC voltage into a series of pulses so that the duration of the pulse is directly related to the value of the DC voltage. When controlling using frequency modulation (FM), the PWM ON period (ON-period) must be kept constant, but the frequency must vary, which brings its own regulation (rules). It is very difficult to keep the ON-period under a certain time duration; when the limit is reached, control using PWM becomes impossible (becomes impossible). This is because PWM control will not be useful when used to transmit a certain amount of information based on a time-division multiplexing system. Thus [12] offers two alternatives to the PWM method based on negative feedback, quantizer sampled and delta-sigma modulation.

If a system has multiple inputs and multiple outputs (MIMO), then the full state feedback method can be used, as stated by [11] in his research using a linear quadratic regulator (LQR), which uses a state-space system in the control system settings that depend on the number of inputs and the order of the controlled system (quadrotor height control). The control strategy greatly determines the final result of a control system that is built, one of which is what [13] did in his research related to hydraulic power generation systems (HPGS) by using PWM as a rectifier so that the incoming current is in the form of a sine wave. (sine wave) to be flexible. This is because HPGS can directly enter the DC nano grid using an uncontrolled rectifier. By applying PWM, the results obtained by HPGS always work on the optimal speed curve.

TABLE I. PID CONTROL SYSTEM STRUCTURE [6]

Parameter	Rise time	Overshoot	Settling time	Steady-state
-----------	-----------	-----------	---------------	--------------

				error
Kp	decrease	increase	small change	decrease
Ki	decrease	increase	increase	decrease significantly
Kd	minor decrease	minor decrease	minor decrease	no effect in theory

PID control (proportional, integral, and derivative) is one of the feedback control methods, which has been widely used in the industrial environment since 1939 and is widely used until now [6] as process control. PID control is understood as controlling with a current state, a previous state, and a future state. Table 1. The structure of the PID control system, which works based on the error signal that occurs $e(t)$.

Proportional control depends on the current error (present-error), integral control is the accumulation of previous errors (past-error), and derivative control will predict future errors (future-error). Proportional control, known as proportional gain (K_p) is a constant value that has been set previously. This K_p value will be multiplied by the error value to see the final response, also known as the proportional response (1). The error value is obtained by comparing the setpoint value with the feedback value from the sensor (actual value).

$$P = K_p \cdot error(t) \quad (1)$$

Integral control counts the number of errors (errors) that occur over time (2) and accumulates that should have been corrected previously, which results in integral control eliminating steady-state errors.

$$I = K_i \int_0^t error(t) dt \quad (2)$$

Derivative control can increase system stability, reduce overshoot, and increase transient response (3). $D_error(t)$ or delta error is the comparison between the current error and the previous error.

$$D = K_d \cdot \frac{Derror(t)}{dt} \quad (3)$$

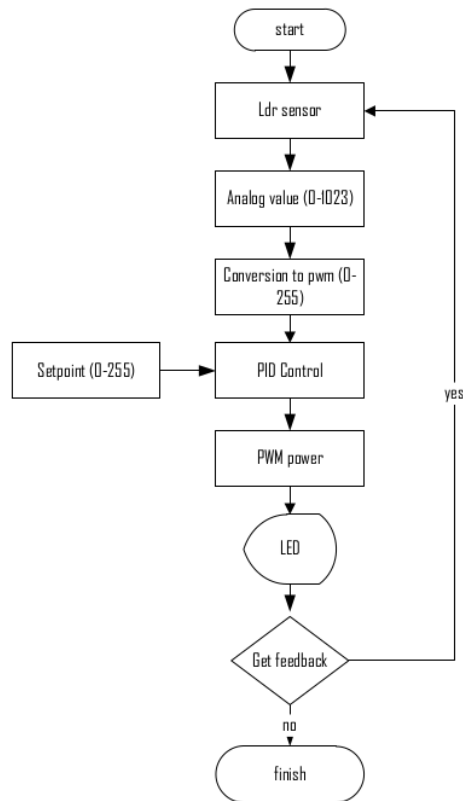

Figure 4. PID dan PWM feedback control flowchart

Figure 4 is a flow diagram of the feedback system, and the LDR sensor is used to read the current (actual) light intensity condition. The sensor reading results (10 bits) will be converted into 8 bits. The design of the LED light brightness control system is shown in Fig. 5. The reference value (setpoint) has been previously set. The LDR sensor will read the brightness level at the test location and be a microcontroller's feedback value. The microcontroller will compare the value from the sensor with the setpoint value given previously. Then the PID algorithm will perform the calculations. The results of these calculations will be sent to the PWM generator, which later, the value generated by the PWM generator will be sent (in the form of pulses) to the LED lamp.

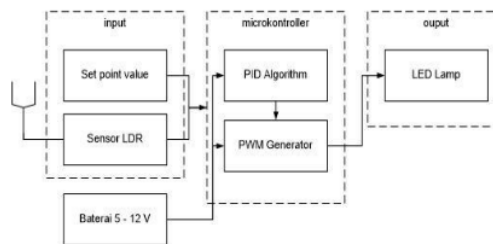

Figure 5. PID dan PWM control system

The LDR sensor is an analog sensor, so the range of values to be stored is between 0 to 1023 (10 bits); this

value will be converted into 8 bits with a range of 0 to 255. This value (8 bits) is the value that the PWM generator will generate. (digital), a value of 0 indicates OFF, and a value of 255 indicates ON. A value between 0 and 255 indicates the brightness level of the LED when it is on. PWM is a modulation technique by changing the pulse width (duty cycle) with a fixed amplitude and frequency. One pulse cycle is a high state and enters the transition process to a low state. As seen in Fig. 6, it is indicated by the magnitude of the voltage flowing to the output (LED lamp).

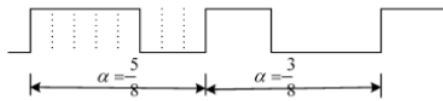

Figure 6. Difference between HIGH and LOW pulses in Pulse Width Modulation [13]

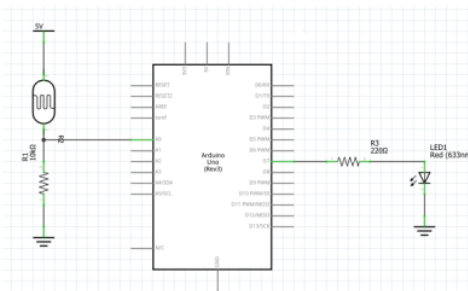

Figure 7. LED Control Schematic with LDR Sensor

Figure 7 is a schematic display of LED control using LDR sensors, testing Arduino Uno Microcontroller, and using Arduino's built-in PID algorithm (PID_V1.h). PID control can also be used to stabilize the output voltage because it is constant and can be maintained, as stated by [14] in his research to control the speed of BLDC motors. It is using DC-DC Bidirectional and PI control as output waveform fix. Research conducted by [15] configures a square wave at a specific frequency where the application to be controlled by a stepper motor requires a constant speed. Due to the nature of stepper motors, it will not rotate when the startup speed is too high, so proper stepping mode is fundamental in stepper motor control.

III. RESULT AND DISCUSSION

There are two stages of testing carried out in this study: reading the input and output. The setpoint value follows the output value with a range (0–255). There are two setpoint values to be achieved in this test, namely setpoint 100 and setpoint 255.

The first stage is to read the input value (signal) from the LDR sensor (analog), the analog input value (10 bits), and the voltage characteristics will be seen. The second stage of testing is to determine the characteristics of the PID control in performing calculations to get the output value. Tests were carried out for each parameter, namely proportional (Kp), integral (Ki), and derivative (Kd). The output of the PID control will be sent to the PWM generator, which has an

output value with a range of 0 to 255 in the form of a signal that is converted into voltage and then will be used to turn on the LED lights. The amount of the output voltage depends on the value generated; for the input and output, the PWM value will be seen, and then the comparison and magnitude will be seen. The amount of load (resistor) used also determines the value of the voltage that will be channeled to the LED lamp.

The test results with a setpoint setting of 100 can be seen in Table 2. The value read on the input (LDR sensor) has a range of 550–1023 (analog); a value of 1023 indicates a very dark condition, and a value of 550 indicates a very light condition. The testing process is carried out one by one, using a small flashlight and in-room conditions without light. To increase and decrease the reading value of the LDR sensor, the position of the flashlight is adjusted up and down until the desired value is reached; as shown in Table 2, the increase in value is set by a distance of 50 points. The voltage on the sensor and also the voltage on the LED lamp is also measured, and it should be noted that in the 10th and 11th tests, the voltage read on the LED lamp is 0 volts, this is because, at that position, the PWM value that is read is above the setpoint value already previously set and the PID control when performing calculations, the input value will be considered as 0 (zero).

TABLE 2. COMPARISON OF INPUT AND OUTPUT VALUES AT SETPOINT 100 NO INPUT OUTPUT

No	Input Sensor (LDR)			Output LED	
	Analog	Voltage LDR	PWM LDR	PWM LED	Voltage LED
1	1023	4.975	1	89	0.725
2	1017	4.932	3	87.2	0.71
3	950	4.672	18	77.9	0.588
4	900	4.471	30	61.9	0.515
5	850	4.178	43	51.4	0.466
6	800	3.925	60	39.6	0.318
7	750	3.72	68	29.7	0.236
8	700	3.454	81	18	0.146
9	650	3.388	94	8.1	0.05
10	600	2.968	102	0	0
11	550	2.755	117	0	0

Likewise, the PID algorithm output will not issue a PWM LED value that exceeds the setpoint value. Figure 8. A graphic form of test results with a setpoint of 100.

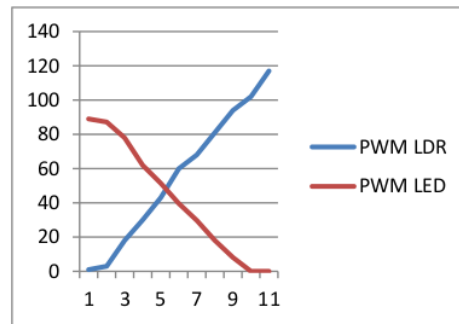

Figure 8. Comparison of input (PWM LDR) and output (PWM LED) values

Table 3 is the result of testing with a setpoint setting of 255 (maximum value of PWM). It is very

interesting to note that the voltage is directly proportional to the input and output for each characteristic value that is read. The smaller the input voltage value, the smaller the voltage value at the output. Meanwhile, the PWM input and PWM output values are inversely proportional because the LDR sensor's analog value is converted back following the received light intensity.

TABLE 3. COMPARISON OF INPUT OUTPUT VALUES AT 255 . SETPOINT

No	Input			Output	
	Sensor (LDR)			LED	
	Analog	Voltage LDR	PWM LDR	PWM LED	Voltage LED
1	1021	4.947	1	228	1.855
2	1015	4.875	3	226	1.837
3	900	4.318	27	206.01	1.63
4	865	4.155	42	192	1.564
5	802	3.87	54	180	1.463
6	750	3.647	68	169.1	1.376
7	705	3.435	79	158.4	1.286
8	650	3.113	92	145.8	1.187
9	600	2.875	106	135	1.073
10	500	2.43	130	112	0.91
11	450	2.145	142	101	0.83
12	400	1.97	150	92	0.748
13	300	1.507	182	68.4	0.548
14	250	1.228	192	56.7	0.455
15	200	1.01	205	45	0.364
16	100	0.493	228	22.5	0.167

Figure 9 is a graphical form of the test results with a setpoint of 255. For analog input, a value of 0 (minimum) indicates a very bright light intensity, and a value of 1023 (maximum) indicates a very dark light intensity. Thus, the higher the PWM value of the LED, the greater the voltage read on the LED lamp.

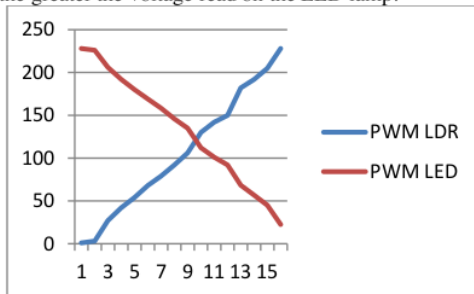

Figure 9. Comparison Graph of Input Value (PWM LDR) and Output Value (PWM LED)

It can be seen from Figure 8 and Figure 9, and the PWM LED output value will not exceed the setpoint value previously set. Meanwhile, the input value (PWM LDR) will still be read but will be considered 0 (zero) by the PID algorithm when performing calculations to determine the output value. Therefore, the next step is to look at the characteristics of each output for each PID coefficient. For this test, the setpoint value is set at the maximum value (255).

A. Proportional Coefficient (Kp)

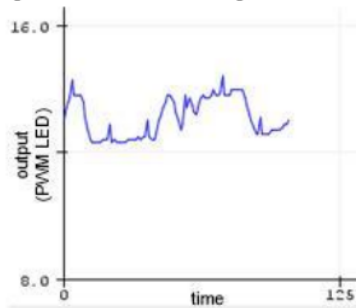

Figure 10. Graph of Signal Coefficient Kp (0.1)

The test was carried out four times for each PID control coefficient. Figure 10 and Figure 11 are test results for proportional coefficients ($K_p = 0.1$ and $K_p = 0.3$). The x-axis represents time, and the y-axis represents the output value or PWM LED.

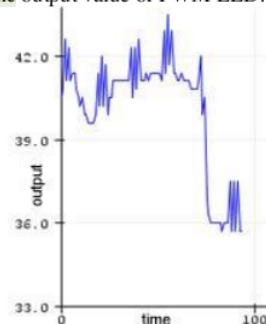

Figure 11. Graph of Signal Coefficient Kp (0.3)

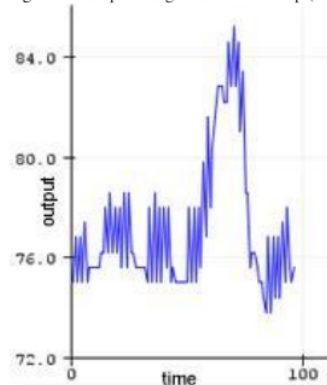

Figure 12. Graph of Signal Coefficient Kp (0.6)

From the testing results, the effect of coefficient values on proportional control is the beginning of the output value (output) calculated by the PID algorithm. The smaller the value of the coefficient, the initial value of the output is also small. In Figure 10, when the K_p coefficient value is 0.1, the output value is in the range 12-14 (PWM LED). When the coefficient value is increased $K_p 0.3$ (Figure 11), the initial output value also increases in the 75-85 range. Likewise for the next

Effect of Pulse Width Modulation on Proportional, Integral, and Derivative Coefficient Characteristics

coefficient values in Figure 12 ($K_p = 0.6$) and Figure 13 ($K_p = 0.9$).

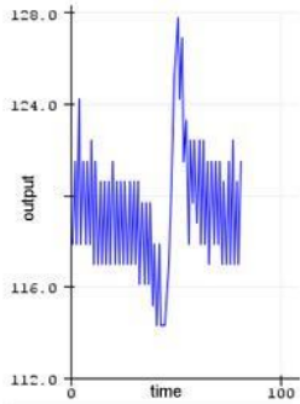

Figure 13. Graph of Signal Coefficient K_p (0.9)

Based on the information in Table 1, when the K_p coefficient increases, the system response speed will increase (increase), the system overshoot will also increase (increase), and the steady-state error will decrease (decrease). It can also be seen from the graph (Figure 10, Figure 11, Figure 12, and Figure 13) that there is a change in the shape of the signal when the coefficient value is increased, it can be concluded that if the value of K_p is large enough then the system will become unstable, this can be seen by the more the number of up and down signals in a short period.

B. Integral Coefficient (K_i)

The test results on the integral control can be seen in Fig. 14 ($K_i=0.1$), Figure 15 ($K_i = 0.3$), Figure 16 ($K_i=0.6$) and Figure 17 ($K_i = 0.9$).

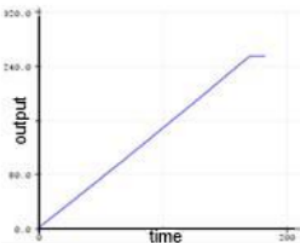

Figure 14. Graph of Signal Coefficient K_i (0.1)

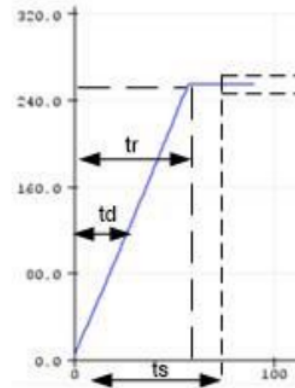

Figure 15. Graph of Signal Coefficient K_i (0.3)

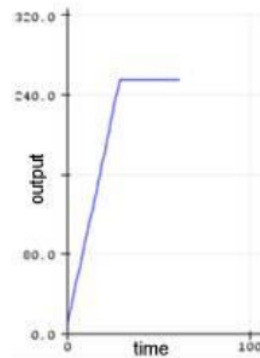

Figure 16. Graph of Signal Coefficient K_i (0.6)

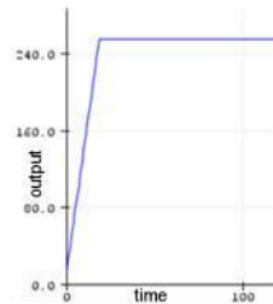

Figure 17. Graph of Signal Coefficient K_i (0.9)

In the integral control, the settling-time (t_s) is shown in Figure 15, which is increasing every time the coefficient value is increased. According to what is stated in Table 1, the settling-time itself can be regarded as a condition, which states that the event (response/reaction) has entered the point approaching the steady-state response or the amount of time it takes to reach the steady-state condition. T_r is the rise-time, and to itself is the time-delay in a system.

C. Derivative Coefficient (Kd)

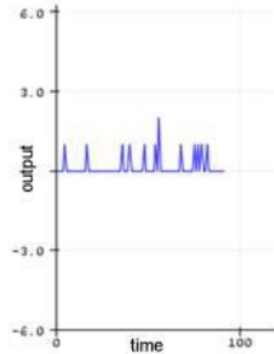

Figure 18. Graph of Signal Coefficient Kd (0.1)

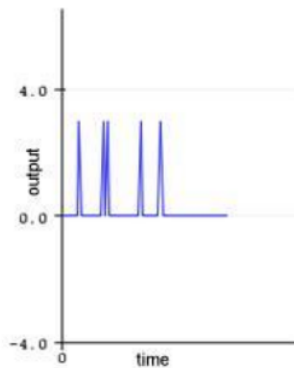

Figure 19. Graph of Signal Coefficient Kd (0.3)

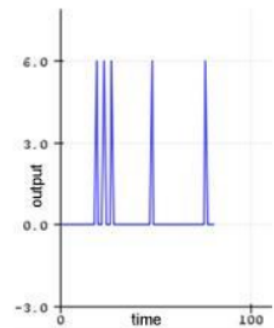

Figure 20. Graph of Signal Coefficient Kd (0.6)

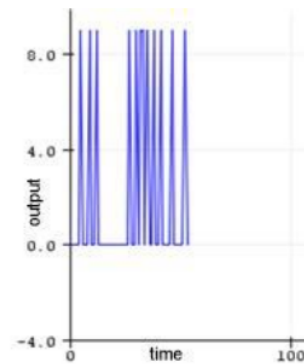

Figure 21. Graph of Signal Coefficient Kd (0.9)

Derivative control is calculating the difference in error in the previous state based on time ($t-1$) and multiplied by the value of the derivative coefficient (K_d), seen in the results of the derivative control test can be seen in Figure 18 ($K_d = 0.1$), Figure 19 ($K_d = 0.3$), Figure 20 ($K_d = 0.6$) and Figure 21 ($K_d = 0.9$), the greater the value of the derivative coefficient, the resulting PID output will follow that value (the bigger it is).

In Figure 18, the coefficient value used is 0.1 and the PID output (output) generated on PWM LED 1, as well as for coefficient 0.3 (PWM LED 3), coefficient 0.6 (PWM LED 6), and coefficient 0.9 (PWM LED 9). The greater the value of the delta error or the difference between the current error (t) and the previous error ($t-1$), the higher the output value produced by the PID will also be.

CONCLUSION

In this paper, the PID control output will be generated by a PWM generator with a range of 0-255, and the output signal is used to turn on the LED lights. The coefficients of K_p , K_d , and K_i have been predetermined for testing with values of 0.1, 0.3, 0.6, and 0.9. The characteristics of the shape of the output signal (output of the PID calculation), which are channeled to the LED lamp, can describe how the PID control works. In testing, analog data from sensors that have a range of 0-1023 data (10bit), known as analog data, is converted into pulses with a range of 0-255 data (8 bits) known as pulse width modulation (PWM). This data, known as feedback, is then used by the PID control to perform the calculation process (mathematically) by comparing it with the setpoint value to find the PID output value (PWM LED), which will later be used by the system to control the brightness level of the LED lights. The greater the PWM value of the LED, the higher the voltage read in the LED lamp and the brighter the light emitted by the LED lamp. From the test results, it can be seen that the adjustment of the coefficient value can be taken based on the amount of difference or error contained in the system. If the error difference is small, the use of a large coefficient value, especially in the derivative coefficient (K_d), is very helpful for the system to achieve stable conditions and reduce the occurrence of overshoot, but

if the error difference value is large, the application of a large coefficient value (K_d) will make the system to achieve this condition. Stability becomes a little difficult because it is possible to overshoot the PID output. From the test results, it is also known that if the value of K_p is large enough, then the system will become unstable. This can be seen by the increasing number of up and down signals in a short time span. Meanwhile, for integral control, it is more directed to the settling-time state, which is a condition that states that the event (response/reaction) has entered at a point approaching the steady-state response or the amount of time required to reach steady-state conditions, will increase (increase.) each time, the coefficient value is also increased.

In this paper, there are still many things that need to be done, especially in the tuning process to find the coefficients of K_p , K_i , and K_d using the Ziegler Nichols method, according to Ziegler Nichols having good performance in dealing with disturbances. Testing the output for the coefficients of K_p , K_d , and K_i needs to be done to see the overall PID control performance.

ACKNOWLEDGMENT

Thank you to the Universitas Maritim Raja Ali Haji for Community Service and Quality Assurance, who provided financial support in carrying out this research.

REFERENCES

- [1] Rendyansyah, E. Exaudi, and A. P. Perdana Prasetyao, "Navigasi berbasis behavior dan fuzzy logic pada simulasi robot bergerak otonom," *J. Nas. Tek. Elektro*, vol. 5, pp. 135–144, 2016.
- [2] G. RaviTeja, M. Shana, and C. Prasanna, "Feedback robustness in structured closed-loop system," *Eropean J. Control*, vol. 57, pp. 95–108, 2021.
- [3] W. Karl, W. M. Mohamed, K. I. M. George, G. G. Raymond, and P. Jürgen, "Interaction of open and closed loop control in mpc," *Automatica*, vol. 82, pp. 243–250, 2017.
- [4] G. F. Michael, S. P. Rohit, H. Hamza, and G. Bhushan, "Model predictive control in industry: challenges and opportunities," *IFAC PapersOnLine*, vol. 48, pp. 531–538, 2015.
- [5] R. B. Rohan, S. P. Gargi, and S. Salunkhe, "Movement control of robot using fuzzy pid algorithm," *IEEE Xplore*, vol. 3rd Intern, pp. 1–5, 2016.
- [6] W. Purbowaskito and C.-H. Hsu, "Sistem kendali pid untuk pengendalian kecepatan motor penggerak unmanned ground vehicle untuk aplikasi industri pertanian," *J. Infotel*, vol. 9, no. 4, pp. 376–381, 2017.
- [7] A. K. Tehrani and A. Mpanda, "Introduction to pid controllers - theory, tuning and application to frontier areas: pid control theory," *intechopen*, 2012.
- [8] A. Pierre, G. Michel, and W. Vincent, "Closed-loop or open-loop models in identification for control?," *IEEE Xplore*, 2015.
- [9] Y. R.T and M. R., "Perancangan sistem kendali pada lengan assistive social robot menggunakan kamera," *J. Nasional Tek. Elektro*, vol. 6, no. 2, pp. 117–122, 2017.
- [10] H. Sira-Ramirez, M. Zribi, and S. Ahmad, "Pulse width modulated control of robotic manipulators," *IEEE Xplore*, 2002.
- [11] D. G. Zrilic, "Alternative approach to use of pulse width modulation," *IEEE Xplore*, 2020.
- [12] R. Faisal Fajri and P. Tri Kuntoro, "Implementasi full state feedback lqr dengan jst pada kendali ketinggian quadrotor," *J. Nas. Tek. Elektro dan Inf.*, vol. 8, no. 4, 2019.
- [13] W. Kunlin *et al.*, "Principle and control strategy of pulse width modulation rectifier for hydraulic power generation system," *ScienceDirect*, vol. 135, no. Renewable Energy, pp. 1200–1206, 2019, doi: <https://doi.org/10.1016/j.renene.2018.12.089>.
- [14] G. A. Prataman, M. K. R. Ananta, R. W. Setia Budi, Dewantara, and I. P. . Diah, "Kontrol kecepatan motor brushless dc menggunakan double boost converter berbasis pi," *Cyclotr. J. Tek. elektro*, vol. 3, no. 1, 2020.
- [15] A. W. Wardhana and D. T. Nugroho, "Pengontrolan motor stepper menggunakan driver drv 8825 berbasis signal square wave dari timer mikrokontroler avr," *Junral Nas. Tek. Elektro*, vol. 7, no. 1, pp. 80–89, 2018.

Effect of Pulse Width Modulation on Proportional, Integral, and Derivative Coefficient Characteristics

ORIGINALITY REPORT

9%

SIMILARITY INDEX

6%

INTERNET SOURCES

6%

PUBLICATIONS

%

STUDENT PAPERS

PRIMARY SOURCES

1	Pierre Ansay, Michel Gevers, Vincent Wertz. "Closed-loop or open-loop models in identification for control?", 1999 European Control Conference (ECC), 1999 Publication	1%
2	www.researchgate.net Internet Source	1%
3	doaj.org Internet Source	1%
4	Kambiz Arab, Augustin Mp. "Chapter 11 PID Control Theory", IntechOpen, 2012 Publication	1%
5	www.ijaemr.com Internet Source	<1%
6	www.skedsoft.com Internet Source	<1%
7	download.atlantis-press.com Internet Source	<1%

8

Rozeff Pramana, Eko Prayetno, Sapta Nugraha. "Sistem Kamera Pengamatan Bawah Laut Berbasis Teknologi Cloud Computing", Jurnal Sustainable: Jurnal Hasil Penelitian dan Industri Terapan, 2018

Publication

<1 %

9

www.diva-portal.se

Internet Source

<1 %

10

www.freepatentsonline.com

Internet Source

<1 %

11

www.repositoriodigital.ipn.mx

Internet Source

<1 %

12

blog.sevagas.com

Internet Source

<1 %

13

enggjournals.com

Internet Source

<1 %

14

Mila Diah Ika Putri, Alfian Ma'arif, Riky Dwi Puriyanto. "Pengendali Kecepatan Sudut Motor DC Menggunakan Kontrol PID dan Tuning Ziegler Nichols", Techno (Jurnal Fakultas Teknik, Universitas Muhammadiyah Purwokerto), 2022

Publication

<1 %

15

Wei Zhao, Byung Hwa Kim, A.C. Larson, R.M. Voyles. "FPGA implementation of closed-loop control system for small-scale robot", ICAR

<1 %

'05. Proceedings., 12th International
Conference on Advanced Robotics, 2005.,
2005

Publication

16 documentserver.uhasselt.be <1 %
Internet Source

17 ir.giec.ac.cn <1 %
Internet Source

18 www.jci.org <1 %
Internet Source

19 Tri Kuntoro Priyambodo, Tonny Suhendra.
"Moving Robot Path Planning Algorithm
Analysis on Dynamic Environment Based
Difference Method Update on Ant Colony
Algorithm", 2018 4th International Conference
on Science and Technology (ICST), 2018
Publication

20 coek.info <1 %
Internet Source

21 eprints.utar.edu.my <1 %
Internet Source

22 rc.library.uta.edu <1 %
Internet Source

23 researchonline.ljmu.ac.uk <1 %
Internet Source

theses.ncl.ac.uk

24

Internet Source

<1 %

25

Djuro G. Zrilic. "Alternative Approach to Use of Pulse Width Modulation", 2006 World Automation Congress, 2006

Publication

<1 %

26

Kunlin Wang, Songwei Sheng, Yaqun Zhang, Yin Ye, Jiaqiang Jiang, Hongjun Lin, Zhenxin Huang, Zhenpeng Wang, Yage You. "Principle and Control Strategy of Pulse Width Modulation Rectifier for Hydraulic Power Generation System", Renewable Energy, 2019

Publication

<1 %

Exclude quotes On

Exclude matches Off

Exclude bibliography On