

# Prototype System to Anticipate Disruption of the IoT-Based Salted Fish Drying Process

**Rahmat Novrianda Dasmien**  
Program Studi Teknik Komputer  
Fakultas Vokasi  
Universitas Bina Darma  
Jl. Ahmad Yani No.3, Palembang  
[rahmat.novrianda.d@gmail.com](mailto:rahmat.novrianda.d@gmail.com)

**Ainan Dinul Haq**  
Jurusan Teknik Elektro  
Fakultas Teknik  
Universitas Bina Darma  
Jl Ahmad Yani No. 3 Palembang  
[ainan271097@gmail.com](mailto:ainan271097@gmail.com)

**Abstract** – As a country that has many islands, our country also has a lot of sea which means it also produces a lot of fish, but fish quickly rot if left alone without a preservation process. One of the preservation processes can be by drying in the sun, but erratic weather can make it difficult for fishermen in the preservation process, therefore a system is made that can detect rain and disturbances such as cats by using a PIR sensor with an automatic control system when it rains or disturbances. It will move the drying into a room that has prepared a heating lamp as a temporary substitute for sunlight. Based on the test results, the LDR and Raindrop sensors successfully read the weather data as given and the system can respond to the data provided by the sensor, Based on the test results, the PIR sensor can read the approaching movement in the dryer area and the safety system is directly active. Based on the results of testing the telegram notification that has been carried out, it was found that there was one failure to be sent out of five attempts. The average photo submission time is 2 seconds.

**Keywords:** Salted Fish Dryer, Ganguan Detector, IoT, Arduino, Telegram.



[Creative Commons Attribution-NonCommercial-ShareAlike 4.0 International License.](https://creativecommons.org/licenses/by-nc-sa/4.0/)

## I. INTRODUCTION

Fish drying is used as a method to preserve fish by minimizing the water content contained in fish so that microorganisms in fish will be reduced, fish preservation using the drying method serves to extend the shelf life of fish. Drying can be done using heat from the sun [1]. Fish is placed in the direction of sunlight because the fish is placed in the open, so there is a possibility that when the weather turns into rain, the fish must be moved quickly, there is also the possibility of interference from the animal that stole the fish. Fish contains 18 percent protein, consisting of essential amino acids that are not damaged at the time of cooking. The fat content is 1-20 percent fat that is easily digested and can be directly used by body tissues. Its fat content is mostly unsaturated fatty acids which can be needed for growth and can lower blood cholesterol [2]. The above problems are experienced by fishermen, they must keep the dried fish from weather changes and disturbances by

animals. The author plans to raise this problem into a thesis by making a tool that can detect weather changes and disturbances by animals by using LDR light sensors that function to respond to light, rain sensors, types of sensors that function to help detect rain, which can be used in all kinds of applications in everyday life. Sensors in this market are sold in module form so only need to provide jumper cables to upgrade to microcontrollers or Arduino. rain drop sensor to detect rain, PIR sensor, The working principle of the PIR sensor is to detect humans through human body movements will output at a high level of 5 volts, if it does not detect humans or no human body movement is detected, the output issued by the sensor is 0 volts [3].

In this study used to detect the movement of animals, all sensors will be controlled by arduino and nodemcu8266 MCU nodes are equipped with micro usb ports that function to transfer programs as well as a voltage source and are equipped with reset buttons and flash. The MCU node uses the Lua messaging language which is a package of esp8266 to send notifications used by nodemcu on this system to send to telegram data from the fish [5].

To make it work effectively, the author will make a storage box that has a slider for drying the fish if the weather is sunny then the fish will be dried in the sun with the heat of the sun and when the weather is not sunny or there is rain, the fish will be automatically put into a storage box that already has an incandescent lamp as a temporary sun replacement, And when there is interference from animals, the system will activate the buzzer and pull the fish into the storage box. After drying reaches 4 hours, the system will notify the telegram to provide information to the fisherman so that the fisherman can turn over the salted fish.

## II. METHOD AND DESIGN

### A. Tool Design

Arduino is a versatile microcontroller that allows it to be programmed. The program in Arduino is usually called sketch. Arduino is an open source platform used to create electronic projects[6]. NodeMCU is one of the microcontroller modules that uses a WiFi system. Its practical use makes

## Prototype System to Anticipate Disruption of the IoT-Based Salted Fish Drying Process

NodeMCU now often used to create electronic projects [7]. Arduino UNO and NodeMCU 8266 have very different specifications. Nodemcu 8266 by default has wifi access which is very suitable for use when creating a project related to IoT, but Nodemcu does not have many pins like Arduino following brief specifications nodemcu 8266.



Figure 1. Nodemcu 8266 Module

PIR (Passive Infra Red) Sensor as figure 3 is a sensor used to detect the presence of infrared light emission. PIR sensors are passive, meaning they do not emit infrared light but only receive infrared radiation from outside [8].

The way this sensor works is to calculate the wavelength produced from body temperature, if the object does not have body temperature, this sensor will not respond, but when objects that have body temperature such as humans or animals, the sensor can respond when the object does not move, even though it has body temperature, this sensor will not respond because there is no drastic temperature change by utilizing the temperature difference between the ambient temperature and body temperature. That is the comparison if the object is stationary then the sensor will respond to it as an ambient temperature. This sensor will not respond to heat if it does not have infrared waves between 8 to 14 micrometers and the range of this sensor is +/- 10 meters and at least +/-30cm



Figure 2. Sensor PIR

RTC (Real-Time Clock) is a battery-powered clock that is included in a microchip in a computer's motherboard. These microchips are usually separate from microprocessors and other chips and are often referred to as "CMOS" (semiconductors of complementary metal oxides)[7]. RTC is a module that we can use to retrieve time data in real time even when the device is turned off because in this module there is a CMOS battery that functions to provide continuous supply so when the device is turned off the module still runs to calculate time in this module we get the value of seconds, minutes and hours even for days this module can be like a date, month and

year on our system this module is used to find out the current clock The RTC chip used in this study is DS3231. The following RTC DS3231 chip is shown in figure below:

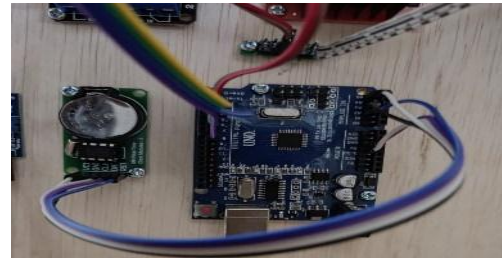

Figure 3. Sensor RTC

LDR or light Dependent Resistor is one type of resistor whose resistance value is influenced by the light received by it. The amount of resistance value in LDR depends on the size of the light received by the LDR itself [8]. LDR stands for Light Dependent Resistor which is one type of resistor component whose resistance value can change according to the intensity of light. The LDR resistance value is strongly influenced by the intensity of light. The lighter the hit, the lower the resistance value. Conversely, if the light is small (dark), then the resistance value becomes greater, so that the electric current flowing will be inhibited [9]. This LDR sensor is more or less the same as the raindrop sensor above, using components and modules to manage its data on the sensor there is an LDR or light dependent resistor, which is a resistor that is sensitive to light, if the higher the light received, the lower the resistance value, on the contrary, if light is not there, the higher the resistance value with this property is used by the module to send data to the microcontroller in this module there is 3 pins namely vcc, gnd and D0 to calibrate data can use the potention meter contained in the sensor module will send 0 or 5v data.

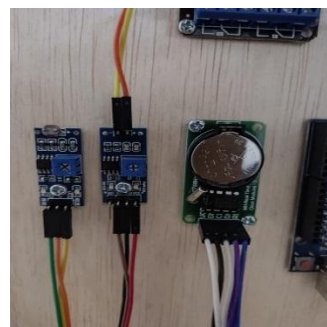

Figure 4. LDR

A rain sensor is a type of sensor that functions to detect the occurrence of rain or not, which can be used in all kinds of applications in everyday life. The working principle of this sensor module is that when there is rainwater falling and hitting the sensor panel, an electrolyzation process will occur by rainwater. And because rainwater is included in the electrolyte fluid group where the liquid will conduct electric current. In this rain sensor there is a comparator ic

## Prototype System to Anticipate Disruption of the IoT-Based Salted Fish Drying Process

where the output of this sensor can be in the form of high and low logic (on or off). The working principle of the conductor plate is the same as the switch. This sensor is in the form of two conductor plates that will be connected when exposed to water. Water can conduct electric current because water is one of the conductors even though it is not a good conductor [11].

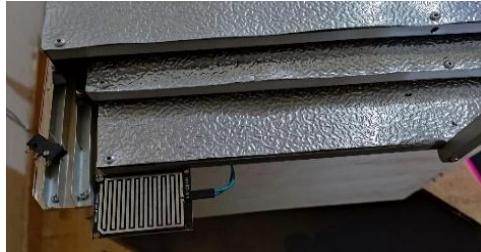

Figure 5. Raindrop Sensor

Relays use the electromagnetic principle to move switches with low power voltage to conduct high voltage electricity. For example, Relays that use 5V and 50mA can be driven by Armature Relays as switches to conduct 220V 2A electricity [12].



Figure 6. Relay

Servo Motor is a type of DC motor with a closed feedback system consisting of a DC motor, a series of gears, a control circuit, and also a potentiometer. So the servo motor actually does not stand alone, but is supported by other components that are in one package. Servo is a device to convert electrical energy into mechanical, then permanent magnet DC servolah motors that convert electrical energy into mechanical energy through the interaction of two magnetic fields. One of the fields is generated by the harvester's magnets and the other is generated by current flowing in the motor coil. The resultant of the two magnetic fields produces torque that generates the rotation of the motor. When the motor rotates, the current in the motor coil produces a torque whose value is constant.[15]



Figure 7. Servo

Motor control can be done using an IC intended as a motor driver. One of the ICs that can be used is ULN2003. This ic has 16 pins and can be used to regulate seven DC motors. [13]. The L298 motor driver is used to control the motor speed based on the PWM value given from the Arduino Mega [4]. L298N motor driver is the most widely used or used DC motor driver module in the world of electronics which is used to control the speed and direction of rotation of DC motors. IC L298 is an H-bridge type IC that is able to control inductive loads such as relays, solenoids, DC motors and stepper motors. IC L298 consists of logical transistors (TTL) with NAND gates that function to facilitate the direction of rotation of a dc motor or stepper motor.



Figure 8. Driver Motor DC

Telegram Messenger is one of the online applications in social media. The app allows users to send text and voice messages, make voice and video calls, and share photos, files, or other media. Applications running on a mobile device can also be connected on a personal computer (PC), as long as the user's mobile device is connected to the internet at the same time to the personal computer. Telegram Bot Application Programming Interface (API) is an open source technology provided by Telegram Messenger LLP for building Telegram bot applications for developers. This bot API is an HTTP-based interface to connect bots developed by developers with the Telegram system [14].

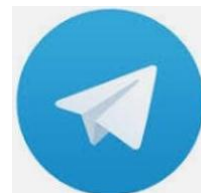

Figure 9. Logo Telegram

The formation of the tool design in the salted fish drying system will be illustrated by a series of schematics. In this study, several components were used, namely Arduino as the main processor that receives data from sensors, sensors contained in this system, among which are PIR sensors function to detect interference, Raindrop and LDR function to take weather data, RTC functions to retrieve time data, and this system has a second processor, namely

## Prototype System to Anticipate Disruption of the IoT-Based Salted Fish Drying Process

nodemcu8266 functions to send data to telegram because this module already has wifi at the output of this system has a servo to flipping the relay fish to turn the heating light on or off The following is the result of the design in the form of a schematic circuit.

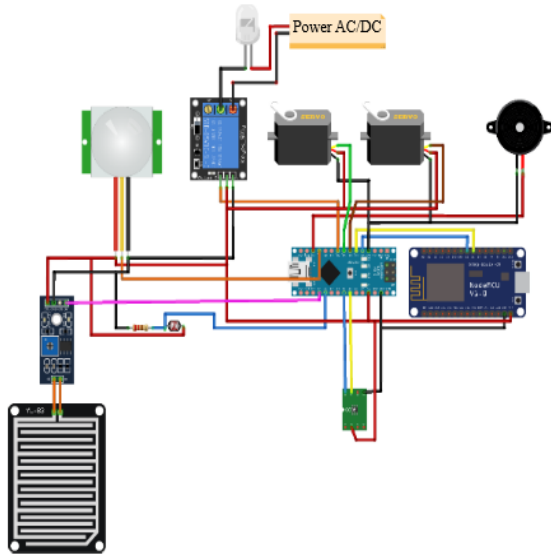

Figure 10. Series Image

### III. RESULTS AND DISCUSSION

This tool is designed by using a prototype first to ensure its use, to get the desired results in this design is arranged into 3 main components, namely input, process and output which can be seen in the block diagram in the picture below.

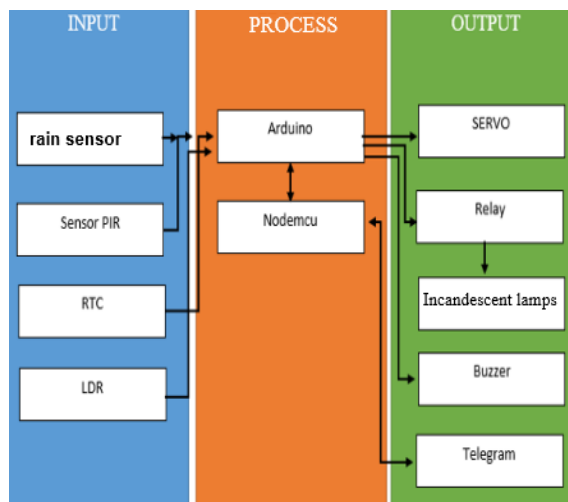

Figure 12. Block Diagram

This stage is the stage of installing task collection monitoring system components on the box with notifications on telegram. How a tool works can be seen from the flowchart or flow diagram of the system process starting until the system is declared complete. When the system is first run, the system will detect the pin pin connected to the microcontroller and save the data into a variable, after that the system checks the rain sensor whether it rains or not, if it rains, the roof of the house will be closed automatically, then turn on the incandescent lamp for solar change, while if it doesn't rain, the system will detect the pear sensor whether there is interference or not, if there is interference, the system will close the roof and turned on the incandescent lamp. if no interference is detected, the system will also check the LDR sensor to make sure the weather is currently sunny, if the weather is dark, the system will close the roof and turn on the incandescent lamp if the weather is not dark and there are no other disturbances, then the system will open the roof to carry out the drying process and the system will check the RTC hammering time, if the drying time has reached 4 hours, the system will turn the fish over. After flipping the fish, the system will send a notification to the telegram, and during the drying process, if the sensor detects a disturbance, the system will send a notification to the telegram. When fishermen go sailing, it is recommended that fishermen have an internet connection connected to a satellite so that they always get a signal to monitor fish drying, in this system telegram is used as monitoring and controlling. The system can receive data from Telegram such as turning off sensors, opening/closing the roof.



Figure 13. Tool Final Results

IV. CONCLUSION

Based on the results of the design and testing of the system as a whole, the conclusion of the tool made is that this drying system will dry based on the weather received by the sensor if it rains / cloudy then uses incandescent lamps otherwise it fully uses energy from the sun, Based on the test results of the LDR and Raindrop sensors successfully read weather data as given and the system can respond to the data provided by the sensor, Based on the test results, the PIR sensor can read the approaching movement in the drying area and the safety system is directly active. Based on the results of testing the telegram notification that has been carried out, it was found that there was one failure to be sent out of five attempts. The average photo submission time is 2 seconds.

REFERENCES

- [1] M. B. Simanjuntak, N. Lustyantje, and I. Iskandar, "Pembelajaran Berbasis Telegram Group dan Microsoft Team di Kelas Bahasa Inggris ( Penilaian berbasis Persepsi Siswa )," vol. 6, pp. 11114–11119, 2022.
- [2] G. C. Lenardo, Herianto, and Y. Irawan, "Pemanfaatan Bot Telegram sebagai Media Informasi Akademik di STMIK Hang Tuah Pekanbaru," *JTIM J. Teknol. Inf. dan Multimed.*, vol. 1, no. 4, pp. 351–357, 2020, doi: 10.35746/jtim.v1i4.59.
- [3] A. Abdul Sofyan, P. Puspitorini, and D. Baehaki, "Cth Ta2," *J. Sisfotek Glob.*, vol. 7, no. 1, pp. 2–2, 2017.
- [4] D. Bulan Fatimah Rahmat, "Sistem Penghindar Tabrakan Depan-Belakang Kooperatif Berbasis Logika Fuzzy," pp. 155–161, 2019.
- [5] A. P. Manullang, Y. Saragih, and R. Hidayat, "Implementasi Nodemcu Esp8266 Dalam Rancang Bangun Sistem Keamanan Sepeda Motor Berbasis Iot," *JIRE (Jurnal Inform. Rekayasa Elektron.* , vol. 4, no. 2, pp. 163–170, 2021, [Online]. Available: <http://e-journal.stmiklombok.ac.id/index.php/jireISSN.2620-6900>
- [6] S. Siswanto, G. P. Utama, and W. Gata, "Pengamanan Ruangan Dengan Dfrduino Uno R3, Sensor Mc-38, Pir, Notifikasi Sms, Twitter," *J. RESTI (Rekayasa Sist. dan Teknol. Informasi)*, vol. 2, no. 3, pp. 697–707, 2018, doi: 10.29207/resti.v2i3.592.
- [7] B. D. Maulana, D. H. Setiabudi, and R. Lim, "Sistem Pengaturan Suhu Dan Kelembaban Kandang Ayam Menggunakan Arduino Dan Website," *J. Infra*, 2020, [Online]. Available: <http://publication.petra.ac.id/index.php/teknik-informatika/article/view/10502>
- [8] D. Desmira, "Aplikasi Sensor Ldr (Light Dependent Resistor) Untuk Efisiensi Energi Pada Lampu Penerangan Jalan Umum," *PROSISKO J. Pengemb. Ris. dan Obs. Sist. Komput.*, vol. 9, no. 1, pp. 21–29, 2022.
- [9] E. Riyanto, "SISTEM KEAMANAN RUMAH BERBASIS ANDROID DENGAN RASBERRY Pi," *J. Inform. Upgris*, vol. 5, no. 1, pp. 55–59, 2019, doi: 10.26877/jiu.v5i1.3214.
- [10] E. Gunawan and A. B. Maulana, "Rancang Bangun Prototype Sistem Penyortiran Barang Melalui Kode Warna (Ourcode) Berbasis Arduino Uno," *J. Cahaya Bagaskara*, vol. 1, no. 1, pp. 22–29, 2017.
- [11] A. Syahputra, K. Lumbanbatu, and S. Utara, "Rancang bangun sistem penjemuran buah pinang otomatis pendeteksi hujan berbasis arduino uno menggunakan metode fuzzy," vol. 6, no. 2, 2022.
- [12] N. Sadikin, M. Sari, and B. Sanjaya, "Smarthome Using Android Smartphone, Arduino uno Microcontroller and Relay Module," *J. Phys. Conf. Ser.*, vol. 1361, no. 1, pp. 0–6, 2019, doi: 10.1088/1742-6596/1361/1/012035.
- [13] R. Ridarmin, F. Fauzansyah, E. Elisawati, and E. Prasetyo, "Prototype Robot Line Follower Arduino Uno Menggunakan 4 Sensor Trct5000," *INFORMATIKA*, vol. 11, no. 2, p. 17, 2019, doi: 10.36723/juri.v11i2.183.
- [14] R. Novrianda Dasmen and . R., "Implementasi Raspbery Pi 3 pada Sistem Pengontrol Lampu berbasis Raspbian Jessie," *J. Edukasi dan Penelit. Inform.*, vol. 5, no. 1, p. 46, 2019, doi: 10.26418/jp.v5i1.29720.
- [15] A. M. Muhammad, "Simulasi Alat Penjaring Ikan Otomatis Dengan Penggerak Motor Servo Continuous, Sensor Jarak Hc- Sr04 Dan Tombol, Menggunakan Arduino Mega," *Simulasi Alat Penjaring Ikan Otomatis Dengan Penggerak Mot. Servo Contin. Sens. Jarak Hc-Sr04 dan Tombol, Menggunakan Arduino Mega*, vol. 12, no. 1, pp. 39–47, 2019, [Online]. Available: <https://journal.stekom.ac.id/index.php/E-Bisnis/article/view/82>