

Design of Audiosonic Frequency Wave Therapy Tool With Arduino Mega-Based Spectrum Analyzer Monitoring

*Florentinus Budi Setiawan

Departement of Electrical Engineering, Faculty of Engineering, Universitas Katolik Soegijapranata
Jalan Pawiyatan Luhur IV/1 Bendan Duwur,
Semarang - Indonesia
f.budi.s@unika.ac.id

Daniel Danin Prasetyo

Departement of Electrical Engineering, Faculty of Engineering, Universitas Katolik Soegijapranata
Jalan Pawiyatan Luhur IV/1 Bendan Duwur,
Semarang - Indonesia
17f10017@student.unika.ac.id

Leonardus Heru Pratomo

Departement of Electrical Engineering, Faculty of Engineering, Universitas Katolik Soegijapranata
Jalan Pawiyatan Luhur IV/1 Bendan Duwur,
Semarang - Indonesia
leonardus@gmail.com

Abstract – As technology develops, more and more devices can produce or record sound waves. There are currently a lot of sound wave generators in use; however, the frequency output range of these generators is highly constrained. This study is being done to help doctors or the general public treat specific illnesses or disorders such as neurological disorders, headaches, and stomach digestion issues. This prototype was created using experimental or lab techniques, by running tests on the variables being utilized. The Arduino Mega 2560 microcontroller is used to operate this prototype. The Arduino Mega 2560 employs the C and C+ programming languages for its code. The Arduino Mega 2560 may be used to modify the keypad's output frequency, amplitude, and data input. This tool is designed to be able to output frequencies of 20 Hz to 20,000 Hz (human sound). In this study, it has an output in the form of frequencies produced from speakers with test frequencies, namely 200 Hz, 10 kHz, and 17 kHz.

Keywords: *Sound Waves, Audiosonic, Arduino, Microcontroller, Frequency Wave Therapy*



[Creative Commons Attribution-NonCommercial-ShareAlike 4.0 International License.](https://creativecommons.org/licenses/by-nc-sa/4.0/)

I. INTRODUCTION

For the previous two years, the season cannot be predicted. The rainy season typically lasts from early October to the end of March, while the dry season, which is now unpredictable, lasts from the beginning of April to the beginning of September. It's possible for heat and rain to both occur on the same day. As a result, the temperature will fluctuate, which will make it challenging for the human body to adjust. Technological advancements in the health field are critical for assisting medical staff facilities and enabling them to help eliminate diseases that affect the community. Due to the speed at which technology is developing right now, it is feasible to securely view and communicate our health status with our physicians or family members [1].

A wave with an audio-sonic type falls within the 20 Hz to 20,000 Hz frequency range. These waves

can still be perceived and heard by humans, depending on their age and level of sensitivity [2]. The ability to hear audio-sonic frequencies will deteriorate with aging in humans [3]. The waveform of sound is longitudinal, and it may travel across an air medium [4].

The replication of realistic sound fields for presence-based communication has recently been the subject of research. Despite not maximizing acoustic echoes, the study continues to employ the surface-checking concept [5] [6]. Because they can observe a variety of engineering aspects, ultrasonic waves have recently been the subject of extensive investigation in the field of health. As far as we are aware, there are several kinds of sound waves, such as audio-sonic, ultrasonic, and infrasonic. There is currently little research on audio-sonic sound waves. Based on this background, researchers studied audio-sonic waves and created prototypes of therapeutic devices employing audio-sonic frequency waves because they thought they might be used in the field of health and were novel.

In making the prototype of this therapeutic tool, wave accuracy testing has been carried out by pressing the keypad according to the required frequency. The use of a spectrum analyzer application on mobile phones as a tool for measuring so that sound intensity (dB) and frequency (Hz) can be known. Before the prototype creation process, the researcher simulates the Proteus application. This therapeutic tool can function as a relaxation tool for sleep to avoid sleep disorders and can be used as an alternative tool to cure diseases such as headaches, stomach pains, and so on. Unfortunately, researchers did not include frequency samples for disease types.

II. BASIC OF THEORY

A. Waves

Waves are vibrational energy propagations that travel through or without a medium. Based on the medium, waves are divided into two types, namely mechanical and electromagnetic waves. As for the

direction of propagation, the wave is divided into two types, namely transverse waves and longitudinal waves. A transverse wave is a wave that has a propagation direction perpendicular to its vibrating direction..

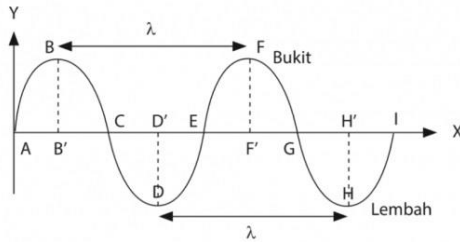

Figure.1 Transverse Waves

Fig. 1 shows that each hill and valley equals one lambda [7]. Meanwhile, a longitudinal wave is a wave whose vibrating direction is parallel to the direction of propagation.

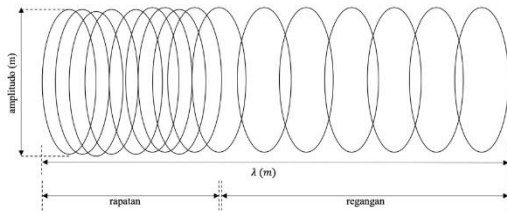

Figure. 2 Longitudinal Waves

In Fig. 2, there are three longitudinal waves, one lamda counting from one density, and one stretch [8].

A sound source creates a mechanical wave of the longitudinal kind when it makes a sound. The sound is produced by a vibrating item, travels through the atmosphere, and is picked up by living things' eardrums. According to the principles of physics, the sound amplitude is measured in decibels, whereas the sound velocity is measured in hertz (HZ) (dB). Different kinds of sound waves include:

1. *Infra - sonic*

Infrasonic waves are a type of wave that has the lowest frequency, which is < 20Hz (less than 20 vibrations per second). This wave cannot be captured by human hearing. Examples of living things that can hear infrasonic waves are dogs, ants, and spiders. Infrasonic waves are a type of wave that has the lowest frequency, which is < 20Hz (less than 20 vibrations per second). This wave cannot be captured by human hearing. Examples of living things that can hear infrasonic waves are dogs, ants, and spiders.

2. *Audio - sonic*

These waves have frequencies between 20Hz to 20 kHz. At this frequency, the human eardrum can capture the waves generated by the sound source.

3. *Ultra - sonic*

Ultrasonic waves have a very high loudness of sound and a frequency of >20kHz (more than 20000 vibrations per second). An example of a living thing that uses this wave is a bat [9].

The reference for calculating the period and frequency of the wave is used as follows formula [10]:

Wave Period Formula

$$T = \frac{t}{n} \tag{1}$$

Wave Frequency Formula

$$F = \frac{n}{t} \tag{2}$$

B. Arduino mega 2560

Arduino is a microcontroller that has open-source properties and in which there is a main component, namely a microcontroller chip of the AVR type designed by the Atmel company [12]. Arduino Mega 2560 is a development of Arduino, which uses the ATmega 1280 chip, but now uses the ATmega 2560 chip. On the Arduino Mega 2560, there are 54 input/output pins (15 pins as PWM), 16 analog input pins, and 4 UART pins (a serial hardware port). The Arduino Mega 2560 is also equipped with a USB port, ICSP header, 16 MHz oscillator, and a reset button.

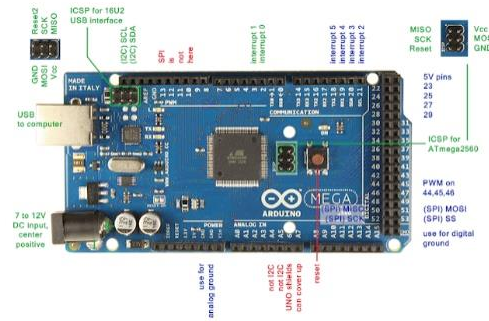

Figure. 3 Arduino mega 2560

Fig. 3, board includes 54 digital input/output I/O pins, 16 analog input pins, and 4 UARTs, and 15 of them are utilized for PWM output signals. The Arduino Mega's input voltage ranges from 7 to 12 V DC.

One of the best-known examples of open-source hardware is the single-board microcontroller known as Arduino. created to make it easier to employ electronics in a range of applications. The system's processor is an Atmel AVR.

C. IC AD9850

The IC AD9850 is an integrated device using DDS technology combined with an internal D/A converter and compiler with high response to form a frequency synthesizer and digitally programmable clock generator function. The AD9850 IC can be programmed with a pure analog output and produces a sine signal. These sine waves can be converted into square waves and used directly as a frequency source for generator applications. When it reaches 20–30 MHz, the harmonics on this device will get bigger, but the waveform will become less and less clean. The high-speed DDS core provides tuning with a frequency of 32 bits that has an output tuning result of 0.0291 Hz for an input reference of 125 MHz [11] [12].

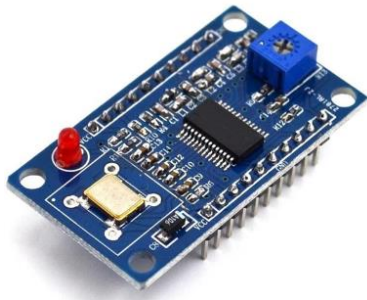

(a)

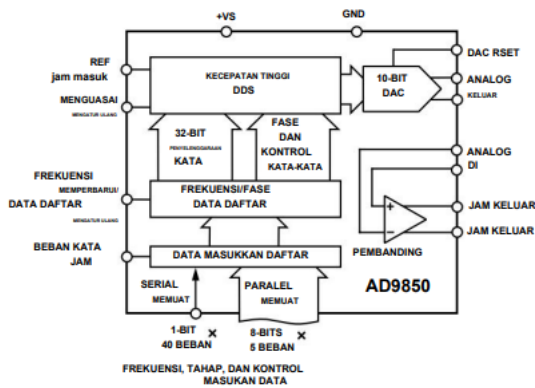

(b)

Figure. 4 (a) IC AD9850 (b) Blok IC AD 9850

Fig. 4, indicates the AD9850 IC, which can generate an output frequency of 62.5 MHz, or can be said to be half of the reference clock. The output frequency can be changed digitally at speeds reaching a frequency of 23 million Hz to produce a gradual displacement of the output phase from 180°, 90°, 45°, 22.5°, and 11.25°, and in each combination, the device provides 5-bit phase modulation. The device has a high comparator configuration designed to receive output and is filtered in the DAC, resulting in a low square wave output. Frequency setting, control, and modulation can be set via parallel bytes. The parallel load format consists of five repeated loads of the 8-bit control word; the first byte controls phase modulation, power down activation, and the loading format, which consists of 2–5 bytes consisting of 32-bit frequency tuning words. Such serial loading is done through a 40-bit serial data stream on a single pin..

D. IC LCD

LCD (Liquid Crystl Display) is a type of device for monitoring using liquid crystals.

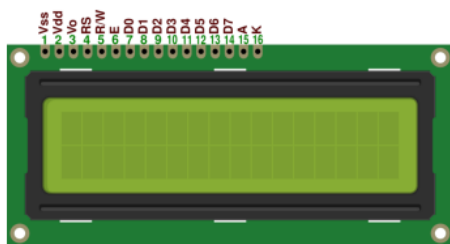

Figure. 5 IC LCD 16x2

Fig. 5 shows the initialization of the 16x2 LCD pins connected from Arduino, namely RS, Enable, D4, D5, D6 and D7 with pins 2, 3, 4, 5, 6 and 7.

E. Keypad matrix 4x4

A matrix keypad is a number of keys arranged so that they form an arrangement of number keys and several other menus.



Figure. 6 Keypad

The keypad is input to Arduino mega 2560. In Fig. 2.6b the 4 x 4 keypad consists of 4 rows and 4 switch columns arranged in each column cross. The input and output sides of this keypad do not bind to each other and can be conPictureured with columns as input and rows as output and vice versa.

F. Amplifier

An amplifier is an electronic device used to maximize output power. The amplifier can amplify the sound signal by amplifying from the input current (I) and voltage (V), while the output produces a greater electric current [13]. The mention of the magnitude of the frequency is called gain power. The power gain in the amplifier is between 100 to 200 times that of the output signal. The unit of Gain power is watts. There are 3 types of reinforcement in amplifiers, namely voltage strengthening, current gain, and power strengthening. Here is the formula for the amplifier:

$$\text{Voltage gain} \tag{3}$$

$$A_v = \frac{V_{out}}{V_{in}}$$

$$\text{Current Gain} \tag{4}$$

$$A_i = \frac{I_{out}}{I_{in}}$$

$$\text{Power Gain} \tag{5}$$

$$A_p = A_v \times A_i$$

III. METHOD AND DESIGN

The research method used by researchers in making tools is a type of experiment, namely, testing and analyzing variables on the keypad in the form of frequency numbers according to the LCD and by the output on the spectrum analyzer. The analysis used in making this tool uses two stages, namely hardware design, system analysis, and software design. The next stage is simulating using the Proteus application to find out the correctness of the system function that has been designed, and the last stage is output testing using speakers with spectrum analyzer monitoring. In this method, researchers used an Arduino Mega 2560,

which has been programmed and connected to a 5 VDC power source.

The components used are the Arduino Mega 2560, keypad, LCD IC, AD9850 IC, amplifier, and ELCO. The use of the Arduino Mega as a 4x4 keypad control to output data in the form of numbers is used to determine frequencies. Next, press the star key (*) on the keypad as an accept sign to start the performance of the therapy tool. If the keypad program is already running, then Arduino instructs the LCD to display the results of the numbers that have been typed on the keypad. The 16x2 LCD will display the words "running in Hz" as a sign that this therapy tool is active, and this tool will output frequencies according to the numbers that have been displayed on the 16x2 LCD. The Arduino, which has been integrated with the keypad and LCD, also has the task of displaying frequency waves that will be processed by the AD9850 IC so that it will produce a signal in the form of a sine wave. The AD9850 IC is also integrated with Arduino to produce a frequency range of 0–20 kHz. Furthermore, the output from the AD9850 IC is connected to the driver. The amplifier is used to amplify the result of the frequency that has been ejected [14].

Researchers used an amplifier with a voltage input of 220 VAC and a current capacity of 5 A in a 5-amp transformer. The amplifier then goes to ELCO to produce a much larger capacitance, so it does not require a choke. From the ELCO, it is then connected to the same driver as the output driver from the AD 9850 IC. The work on this tool produces output in the form of sound waves connected to speakers. Furthermore, the sound coming out of the speaker is measured using a spectrum analyzer to find out whether the frequency produced is appropriate or not, as well as what the noise level (dB) is. The way to reset this tool is by pressing the C key.

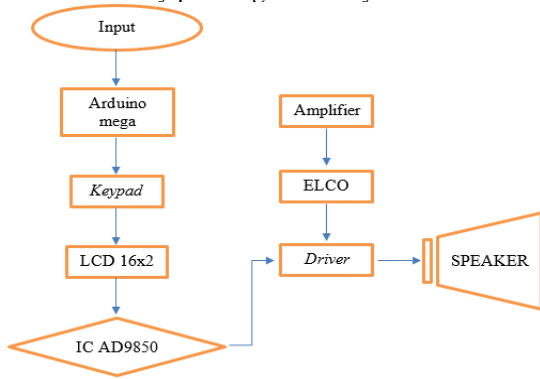

Figure. 7 Workflow flowchart

IV. RESULTS AND DISCUSSION

In making this prototype of a therapeutic tool, there are 2 stages, namely the simulation stage and the hardware testing stage. Frequencies used include 200 Hz, 10 kHz, and 17 kHz. The researcher chose these 3 frequencies because of the limited speaker capacity used by the researcher, if using a frequency of < 200 Hz the bass sound is very high, and if > 17 kHz the sound is not heard by the researcher.

1. Simulation Results

After the program is created using arduino software, the next step is to create a simulation using proteus. This simulation is to display numbers on the LCD display according to the numbers typed on the keypad. Making this simulation is useful as a reference for implementation into the form of hardware and program trials that have been made can run as desired, so as to reduce errors when working on this tool. In this simulation, it displays the frequency input that has been typed using the keypad and then displayed on the LCD. The following are the simulation results:

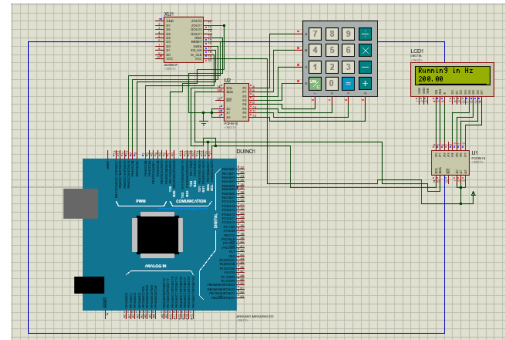

Figure. 8 simulations using a frequency of 200 Hz

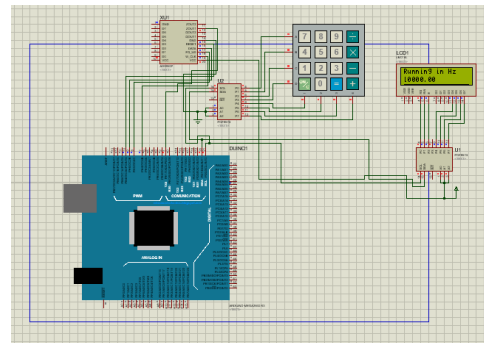

Figure. 9 simulations using a frequency of 10 kHz

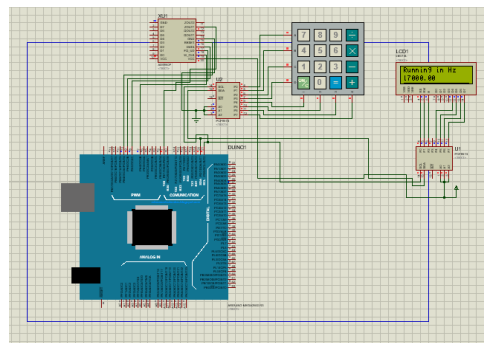

Figure. 10 simulations using a frequency of 17 kHz

The results of the three simulations can be displayed well and are appropriate on the LCD.

2. Hardware Testing

Based on the research findings, it is possible to conclude that a proteus simulation process is required to display frequency numbers in the LCD based on the type of keypad. In the trial, the speaker could output sound with frequencies of 200 Hz, 10 kHz,

and 17 kHz with a monitoring spectrum analyzer corresponding to the input typed using the keypad. This means that programs from the keypad and LCD can emit frequency waves so that the AD9850 IC can convert those waves into sine signals. The disadvantage of this tool is that speakers that are not capable of supporting this therapeutic device must be replaced. Because there is no specific frequency sample for different types of diseases, it must be created from scratch:



(a)

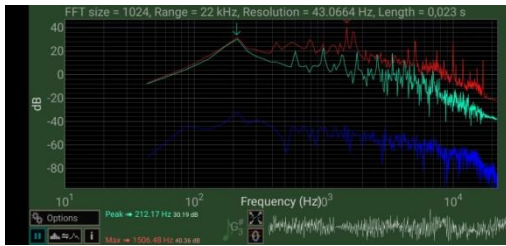

(b)

Figure. 11 (a) 200 Hz frequency display on LCD (b) 200 Hz frequency monitoring on spectrum analyzer



(a)

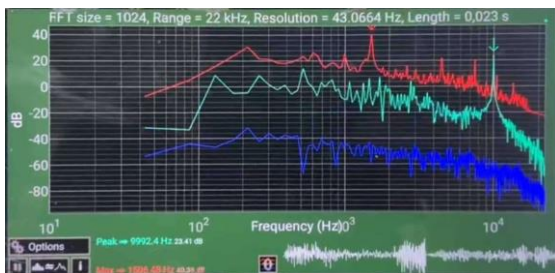

(b)

Figure. 12 (a) 10 kHz frequency display on LCD (b) monitoring of 10 kHz frequency on spectrum analyzer



(a)



(b)

Figure. 13 (a) 17 kHz frequency display on LCD (b) monitoring of 17 kHz frequency on spectrum analyzer

The results of the trial show that the green line is the spectrum line used. There are differences in the spectrum analyzer display for frequencies of 200 Hz, 10 kHz, and 17 kHz, namely the frequency and intensity of the sound are opposite, the lower the frequency, the higher the sound intensity, and vice versa.

V. CONCLUSION

Based on the findings of the research, it is possible to conclude that a proteus simulation process is required to display frequency numbers in the LCD from the keypad type. In the trial, the speaker could output sound with frequencies of 200 Hz, 10 kHz, and 17 kHz with a monitoring spectrum analyzer corresponding to the input typed using the keypad. This means that programs from the keypad and LCD can emit frequency waves so that the AD9850 IC can convert those waves into sine signals. The disadvantage of this tool is that speakers that are not capable of supporting this therapeutic device must be replaced. Because there is no specific frequency sample for different types of diseases, it must be created from scratch.

REFERENCES

- [1] Rosidin, U., Sumarni, N., &Suhendar, I. (2019). Penyuluhan tentang Aktifitas Fisik dalam Peningkatan Status Kesehatan. Media Karya Kesehatan, 2(2). <https://doi.org/10.24198/mkk.v2i2.22574>
- [2] Federico Milano; Alvaro Ortega Manjavacas, "Frequency Control," in Frequency Variations in Power Systems: Modeling, State Estimation, and Control , IEEE, 2020, pp.205-225, doi: 10.1002/9781119551881.ch7.

- [3] Kustaman, R. (2018). BUNYI DAN MANUSIA. ProTVF, 1(2), 117. <https://doi.org/10.24198/ptvf.v1i2.19871>
- [4] Yasid, A., Yushardi,), Rif'ati,), &Handayani, D. (n.d.). PENGARUH FREKUENSI GELOMBANG BUNYI TERHADAP PERILAKU LALAT RUMAH (*Musca domestica*).
- [5] Kanazawa Daigaku, 2017 56th Annual Conference of the Society of Instrument and Control Engineers of Japan (SICE) : 19-22 Sept. 2017.
- [6] N. Ueno, S. Koyama, and H. Saruwatari, "Sound field recording using distributed microphones based on harmonic analysis of infinite order," IEEE Signal Process Lett, vol. 25, no. 1, pp. 135–139, Jan. 2018, doi: 10.1109/LSP.2017.2775242.
- [7] Handika, F., &Fatahillah, D. A. (2019, March). Bentuk polinom gelombang transversal dengan pembuktian deret taylor dengan sisa. In Prosiding Seminar Pendidikan Matematika dan Matematika (Vol. 1, pp. 23-28).
- [8] DJATI, U. S. G. GELOMBANG BERDIRI LONGITUDINAL.
- [9] Pratiwi Pujiastuti, M. P., & Laisaroh, A. PROGRAM STUDI PENDIDIKAN DASAR PROGRAM PASCASARJANA UNIVERSITAS NEGERI YOGYAKARTA.
- [10] Siahaan, J,Syarif, Y, dan Siregar,F,(2018), Rancangan Power Amplifier Untuk Alat Pengukur Transmission Loss Material Akustik Dengan Metode Impedance Tube, 1(2): 55-59
- [11] European Microwave Association, Institute of Electrical and Electronics Engineers, IEEE Microwave Theory and Techniques Society, & European Microwave Week (2017: Nuremberg, G. (n.d.). 2017 47th European Microwave Conference : 10-12 October 2017, Nuremberg, Germany
- [12] [1]D.Dewatama, M. Fauziyah, and N. K. Jannah, "Sistem Pengaturan Pencahayaan pada Budidaya Jamur Tiram Berbasis Arduino Uno Dengan Metode Fuzzy Logic," PROtek: Jurnal Ilmiah Teknik Elektro, vol. 9, no. 2, p. 99, Sep. 2022, doi: 10.33387/protk.v9i2.4319.
- [13] [1]K. Ain, S. Soelistiono, R. A. Wibowo, L. Muniroh, T. Anggono, and W. W. P. Sari, "Design and Development of Device to measure Body Fat using Multi-frequency Bio-impedance Method," Journal of Physics: Conference Series, vol. 1120, p. 012043, Nov. 2018, doi: 10.1088/1742-6596/1120/1/012043.
- [14] Ain, K., Wibowo, R. A., Soelistiono, S., Muniroh, L., &Ariwanto, B. (2020). Design and development of a low-cost Arduino-based electrical BioImpedance Spectrometer. Journal of Medical Signals and Sensors, 10(2), 125.