

# The Performance of Clay-based Biomass Briquette Stove with Three Geometry Shape Variations

*by* PROtek PP Unkhair

---

**Submission date:** 12-Apr-2023 05:42PM (UTC+0700)

**Submission ID:** 2062429915

**File name:** 5845-15677-1-RV.docx (846.23K)

**Word count:** 3404

**Character count:** 17967

# The Performance of Clay-based Biomass Briquette Stove with Three Geometry Shape Variations

**Sallolo Suluh**

Student of Doctoral program of Mechanical Engineering Department, Faculty of Engineering, Universitas Hasanuddin Jl. Poros Malino Bontomarannu Gowa, 92171, Sulawesi Selatan, Indonesia  
email: [sallolonel@gmail.com](mailto:sallolonel@gmail.com)

**Mohammad Yusuf**

Student of Undergraduate program of Mechanical Engineering Department, Faculty of Engineering, Universitas Hasanuddin. Jl. Poros Malino Bontomarannu Gowa, 92171, Sulawesi Selatan, Indonesia  
email: [muh.ucu98@gmail.com](mailto:muh.ucu98@gmail.com)

**Muhammad Irsyad Fauzi**

Student of Undergraduate program of Mechanical Engineering Department, Faculty of Engineering, Universitas Hasanuddin Jl. Poros Malino Bontomarannu Gowa, 92171, Sulawesi Selatan, Indonesia  
email: [Irsyadfauzi680@gmail.com](mailto:Irsyadfauzi680@gmail.com)

**Novriany Amaliyah**

Mechanical Engineering Department, Faculty of Engineering, Universitas Hasanuddin. Jl. Poros Malino Bontomarannu Gowa, 92171, Sulawesi Selatan, Indonesia  
email: [novriany@unhas.ac.id](mailto:novriany@unhas.ac.id)

**Zuryati Djafar**

Mechanical Engineering Department, Faculty of Engineering, Universitas Hasanuddin. Jl. Poros Malino Bontomarannu Gowa, 92171, Sulawesi Selatan, Indonesia  
email: [\\*Zuryatidjafar@unhas.ac.id](mailto:*Zuryatidjafar@unhas.ac.id)

**Wahyu Haryadi Piarah**

Mechanical Engineering Department, Faculty of Engineering, Universitas Hasanuddin. Jl. Poros Malino Bontomarannu Gowa, 92171, Sulawesi Selatan, Indonesia  
email: [wahyupiarah@unhas.ac.id](mailto:wahyupiarah@unhas.ac.id)

**Abstract** – This study aims to determine the best performance of the biomass stove from three types of clay material stove shapes in different configurations of geometric variations. The three variations of the geometric shape of the stove are cylindrical, rectangular, and hexagonal using biomass material from coconut shell charcoal. The uniqueness of this stove is in the addition of a sleeve diameter of 180mm in the stove's combustion chamber as heat insulation. The test results showed that the cylindrical stove was superior to the two in terms of flame temperature, ability to boil water, and thermal efficiency of 798°C, 30 liters, and 73.66%, respectively.

**Keywords:** performance, biomass stove, clay, cylinder, rectangular, hexagonal



**12** Creative Commons Attribution-NonCommercial-ShareAlike 4.0 International License.

## I. INTRODUCTION

One alternative energy source from new and renewable energy is energy from biomass. Biomass is an organic material produced through a photosynthetic process, both in the form of products and waste. The

type of biomass that is often used is a coconut shell, in this case, coconut shell waste, and processed into charcoal briquettes. Njengah et al. [1] in his research stated that coconut shell charcoal briquettes can reduce levels of harmful emissions, reduce deforestation and increase energy. Arief and Suluh [2] in their investigation also used coconut shells as fuel in a briquette stove and obtained a calorific value of 4996 cal/gram with an efficiency value of 71.7%. Yulia et al. [3] in his study combined rice husk and coconut shell and produced a calorific value of 4966 kcal/kg at a mixture ratio of 50:50, while Amoako and Mensah et al. [4] in their research about the calorific value of coconut shells produced 17 MJ/kg. Luke et al. [5] in his research, have mixed zalacca seed charcoal with coconut shell charcoal and obtained a combustion calorific value of 6062 cal/gr with a mixture ratio of 40:60. Musabbikah et al. [6] have also researched the calorific value of coconut shells and found 4667 kcal/kg. Likewise, Sagdinakiadtikul and Supakata [7] in their research, have obtained the highest calorific

value of 4580.5 kcal/kg with a mixture of straw and coconut shell mixture of 20% and 80%.

To transfer the energy contained in the briquettes, a direct combustion stove is used, so that the heat generated can be used for cooking. The existing briquette stove still produces low thermal efficiency, so it is necessary to modify the stove's combustion chamber to increase efficiency. Several studies have made modifications to the biomass stove, including Suluh et al. [8] modified the material in the combustion chamber of a briquette stove made of steel which was able to produce a performance of up to 52.14%. Djafar et al. [9] conducted tests on three types of biomass stove materials namely clay, steel, and aluminum in the shape of a cylinder with the addition of a 180 mm diameter sleeve using coconut shell charcoal briquettes and produced the highest thermal efficiency of 73.66% on the clay stove. Suluh et al. [10] have also made modifications to the combustion chamber of a clay stove with a 90 mm diameter sleeve resulting in a thermal efficiency of 70.73%. While Wang et al. [11] have modified the briquette stove used by adjusting the secondary air duct to produce a thermal efficiency of up to 68%. Orhevba et al. [12] made modifications to the combustion chamber of the stove with an insulin cylinder so that the thermal efficiency was 57.2%. Tyagi et al. [13] provided modifications to the combustion chamber of 4 types of stoves with exergy and energy analysis and produced the highest thermal efficiency of 23.50% on the Envirofit stove model.

In another study, Akolgo et al. [14] examined the method that must be carried out so that the biomass stove has high efficiency and little smoke by modifying the stove's combustion chamber with a gasifier system. Guerrero et al. [15] modified the combustion chamber of the stove by using inert ceramic foam (silicon carbide). The porous ceramics are placed in three configurations (floor, wall, and roof) in one space, and the biomass is burned. Early wood stove combustion tests showed that porous ceramics increased fuel wood burning rate, exhaust, gas and external surface temperatures, and carbon dioxide emissions. Final combustion test results show that for all configurations the particulate emission factor decreases by at least 20%. Porous ceramics are located on the walls of the combustion chamber configuration with the highest increase, reaching 61%. Verma and Sukhla [16] have modified a stove with a cold phase and a hot phase to produce a thermal efficiency of 46.11% and 44%. Rasoulkhani et al [17], have analyzed some of the performance of traditional

stoves with modified biomass stoves by adding two concentric cylinders equipped with two sets of primary and secondary air inlets using apple pruning waste biomass. The results show that the flame increase and the temperature of the water at the time of boiling are the same. Biomass stoves have better thermal efficiency than traditional stoves by around 35%. Likewise, the specific and total fuel consumption is 73% and 67% lower than traditional metal stoves. Murali et al. [18] have modified a wood stove by adding a catalytic combustion chamber using coconut shell charcoal briquettes, sawdust, and sugarcane bagasse as fuel. The results of the combustion test showed that the highest thermal efficiency of the wood stove was 63.63% using coconut shell charcoal briquettes, then followed by sawdust briquettes at 61.62% and sugarcane bagasse at only 53.85%. Panwar [19] has conducted a test comparison of gasifier stoves and household stoves modified in double. The results of the combustion test showed that the thermal efficiency of the gasifier stove tended to be low, only 22.1%, but this household stove could reduce emissions two times that of the gasifier stove. Ahiduzzaman and Sadman Islam [20] have developed a biomass stove made of fire-resistant bricks and clay. The heat from the briquette stove is used as a substitute for electric heating. The biomass stock raises the temperature of the dead barrel to the desired level for making briquettes. The stove provides heat for the barrel dies instead of electric heating. Test results show performance by replacing a 6-kW electric heater in this study.

Based on studies that have been conducted previously, more discussed the utilization of biomass stove heat for more efficient briquette performance, stove modifications to reduce harmful emissions generated, modification of stove heat insulation in the combustion chamber, modification of stove materials, and simulation of insulation materials in the combustion chamber. Only a few research the geometry of the stove from the same stove material. Therefore, in this study, it was intended to conduct a study comparing the performance of three variations of the shape of the biomass stove on the same material, namely clay.

## II. METHODOLOGY OF RESEARCH

The testing was carried out on three variations of the shape of the stove, namely cylindrical, rectangular, and hexagonal stoves with the same dimensions for the three types of stoves, both in area and height, namely the inner diameter of 200 mm, height of 300mm, the

distance between the briquette holder and the base of the stove is 100mm. The biomass briquettes used were honeycomb-shaped coconut shell charcoal briquettes [2] with an inner diameter of 15mm and an outer diameter of 65mm and a height of 45mm. This briquette has 4 small holes that surround it, with a diameter of 8mm for each hole, and weighs 145 grams for 9 pieces of briquettes in each stove. In the combustion chamber of the stove, an aluminum sleeve with a diameter of 180mm, a height of 150mm, and a thickness of 0.9 mm [2] is added, which functions as a heat insulator from the briquettes.

A pan filled with water with a capacity of 5 kg is placed on the stove. This is intended as a test parameter in determining the ability of the stove to transfer heat to the pan until boiling occurs. This method is carried out simultaneously with the three forms of the clay stove with the volume and mass of the briquettes used. The volume of water and the mass of the fuel before and after the combustion process is measured to obtain the combustion efficiency value. The three geometric shapes of the clay material briquette stove can be seen in Figures 1, 2, and 3.

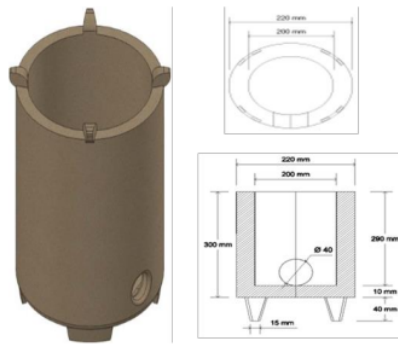

Figure 1. A Cylindrical Stove with Dimensions

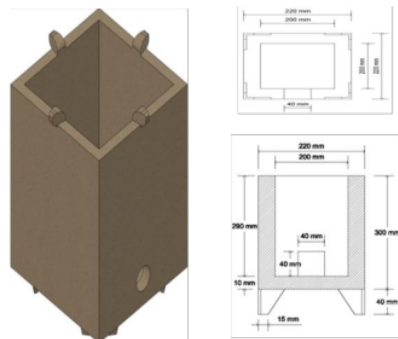

Figure 2. A Rectangular Stove with Dimensions

Figures 1 to 3 show variations of the three forms of stoves in the front view, equipped with the dimensions and sizes of each shape of the stove.

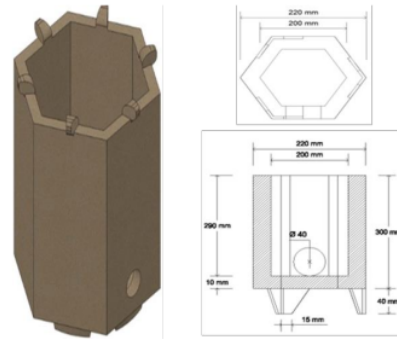

Figure 3. Hexagonal Stove with Dimensions

The test method is carried out as shown in Figure 4, where the data collection process is acquired using the LabVIEW application [21], and the temperature sensor uses a type K thermocouple cable. The test parameters in this study are measuring the temperature of the flame ( $T_f$ ), the temperature of the sleeve wall ( $T_s$ ), the temperature of the combustion chamber, the stove wall temperature ( $T_{sw}$ ), the water temperature ( $T_w$ ) in the pot, and the pot temperature ( $T_{pw}$ ) and ambient temperature ( $T_a$ ).

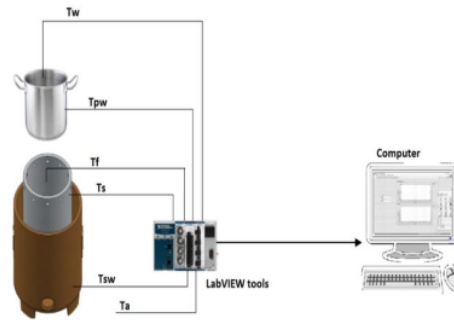

Figure 4. Experimental Installation

### III. RESULTS AND DISCUSSION

Figure 5 shows the history of fire temperature on the three types of clay biomass stove forms. The three forms of clay stoves were modified by adding sleeves to each combustion chamber. The highest fire temperature was produced on a cylindrical briquette

stove of 798°C in the 56th minute, followed by a hexagonal stove of 628.55°C in the 80th minute and a rectangular stove of 587.98°C in the 19th minute. It can be seen that the fire temperature of a cylindrical stove is approx. 20 minutes tends to be stable, then decreases and irregularly until the temperature is below 300°C. In this case, the duration of data collection is limited to 240 minutes. The flame temperature is higher than the other two forms. This happens because the heat transfer of the briquettes is radiated to the combustion chamber of the stove wall completely, without any loss of energy. As research conducted by Kumar M, et al [22] said the thermal efficiency of the stove increases because it is influenced by the wide geometry of the stove, without any loss of energy. According to Mac Carty, et al [23] that the process of heat transfer and fluid flow increases so that the fire temperature in the combustion chamber increases supported by the stove material which has a low level of thermal conductivity, and the geometry of the stove which is designed to be minimal without any gaps on the surface of the stove to avoid the occurrence of energy loss.

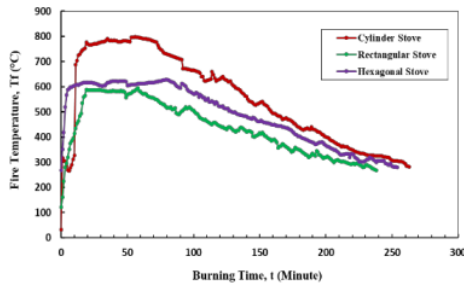

Figure 5. History of Fire Temperature

The history of the wall temperature of the three types of stove shapes is shown in Figure 6. It can be seen that the highest wall temperature was the cylindrical stove at 239.79°C, followed by the hexagonal stove at 178.97°C and the rectangular shape at 167.94°C. The phenomenon that occurs in the figure shows that there is a transfer of radiant heat from the briquettes to the combustion chamber of the stove without any gaps and corners on the walls of the sleeve, causing an increase in the temperature of the combustion chamber. The results of this experiment are matched with the results of research conducted by Sahu et al [24] concerning heat transfer and natural convection in heated cylindrical and rectangular shapes of different sizes developed with fluent and

experimental simulations and concluded that the rate of heat transfer is relatively high on the cylinder base.

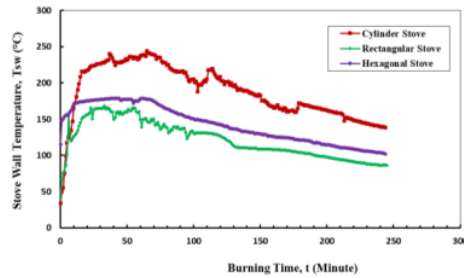

Figure 6. History of Stove Wall Temperature

Meanwhile, Figure 7 shows the relationship between variations in the shape of the stove and the ability to boil water. It can be seen that the best ability to boil water is 30 liters (six times the process of boiling water) on a cylindrical stove, followed by a hexagonal and rectangular stove with 25 liters and 15 liters respectively. The cylindrical stove is superior to the two because it has a large enough combustion chamber without gaps/corners so that the heat transfer rate increases quickly. This analogy can refer to the results of the research by Tehmina et al. [25] that the wide geometry behind the sharply angled fins worsens convective heat transfer. The advantages of heat transfer using cylindrical geometry are also confirmed by Li., et al. [26] who conducted research on heat transfer in two-phase duplet flow in a cylindrical microchannel geometry and showed that the increase in the Nusselt value was two times greater so that the increase reached 40% and 50%.

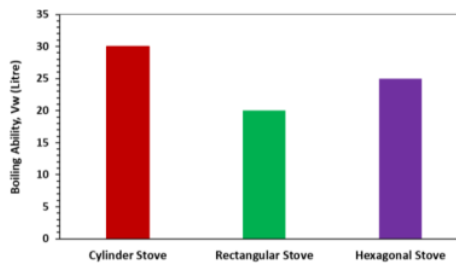

Figure 7. Variations in the shape of the stove and water boiling ability.

Furthermore, Figure 8 displays the mass of the burnt briquettes in the three clay stove forms tested. From the research, it was found that the mass of the most burnt briquettes was 1.26 kg on a cylindrical

stove, then on a hexagonal stove of 1.23 kg, and a rectangular stove of 0.53 kg. On a rectangular clay briquette stove, a few burnt briquettes are seen due to the short (not long) ignition process with a low-temperature value due to the loss of energy distributed over a large angle deviation. This phenomenon can be referred back to the results of the research by Tehmina et al. [25] who said that the heat transfer flow is poor convectively because the wide fin-fin shape has a sharp angular deviation.

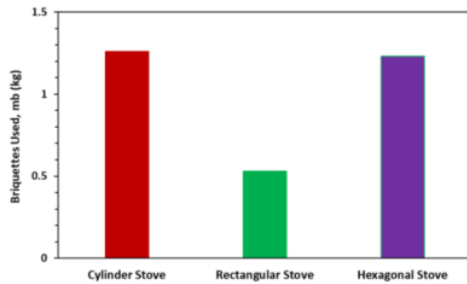

Figure 8. Total mass of burnt briquettes to variations in the shape of a clay stove

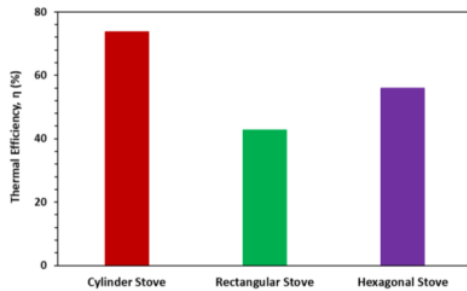

Figure 9. Variations in the shape of the stove to the resulting thermal efficiency

Figure 9 shows the relationship between variations in the shape of the stove on thermal efficiency. The best thermal efficiency value is owned by a cylindrical stove at 73.66%, then a hexagonal stove at 55.92%, and a rectangular stove at 42.78%. It can be seen that the heat transfer in a cylindrical stove can distribute heat evenly in all parts of the combustion chamber.

The relationship between the variations in the shape of the stove and the rate of heat transfer is shown in Figure 10. It can be seen that the highest heat transfer rate was produced by a rectangular stove, at 28.48 watts, followed by a hexagonal stove at 23.45 watts, and a cylindrical shape at 18.78 watts. The heat

transfer rate of rectangular stoves is higher due to the presence of a flat surface which accelerates heat transfer compared to the cylindrical surface, this also has the consequence of decreasing the effectiveness of the stove.

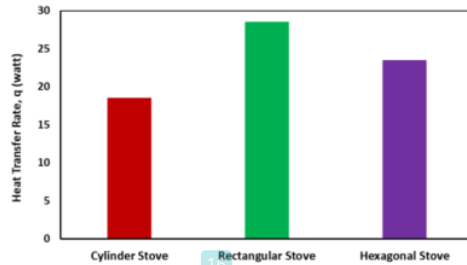

Figure 10. variations in the shape of the stove to the rate of heat transfer that occurs on each stove

#### IV. CONCLUSION

Based on the results of calculations and analysis, it can be concluded that the highest flame temperature produced is 798°C on a cylindrical stove with the ability to boil the most water on a cylindrical stove of 30 liters with a thermal efficiency is 73.66%. On the other hand, the heat transfer rate obtained in a cylindrical stove is the smallest compared to the other two forms of rectangular and hexagonal stoves.

#### REFERENCES

- [1] Njenga, M., Karanja, N., Karlsson, H., Jamnadass, R., Iiyama, M., Kithinji, J. and Sundberg, C. (2014). Additional cooking fuel supply and reduced global warming potential from recycling charcoal dust into charcoal briquettes in Kenya. *J. Clean Prod.*, 81. 81–88. 2014, doi: <https://doi.org/10.1016/j.jclepro.2014.06.002>.
- [2] Arif, E. and Suluh, S. (2014). Study of Performance Improvement of Various Stoves with Waste Biomass Briquettes Fuel. The 1<sup>st</sup> International Symposium on Smart Material and Mechatronics Graduate School of Mechanical Engineering University of Hasanuddin, 72.
- [3] Yuliah, Y., Kartawidjaja, M., Suryaningsih, S. & Ulfi, K. (2017). Fabrication and characterization of rice husk and coconut shell charcoal-based bio-briquettes as alternative energy source. doi: <https://iopscience.iop.org/article/10.1088/1755-1315/65/1/012021>
- [4] Amoako, G., & Mensah-Amoah, P. (2018). Determination of Calorific Values of Coconut Shells and Coconut Husks. *J. Materials Science*

- Research and Reviews, 2(2), 1–7. doi: 10.9734/JMSRR/2019/45639.
- 5 Lukas, A.G., Lombok, J.Z. & Anom, I.D.K. (2018). Briquettes made with mixtures of salak seed (*Salacca zalacca*) charcoal and coconut shell charcoal and the potential as an alternative Energy Source. *Int. J. Appl. Eng. Res.*, 13(12), 10588–10592.
  - 6 Musabbikhah, H. Saptoadi, Subarmono, & M. A. Wibisono, (2016). Optimization of temperature and time for drying and carbonization to increase calorific value of coconut shell using Taguchi method. *AIP Conf. Proc.*, 1717. doi: 10.1063/1.4943430.
  - 7 Sagdinakiadtikul, T. & Supakata, N. (2015). The Application of using Rice straw Coconut Shell and Rice Husk for Briquette, *Int. J. Energy, Environ. Econ.*, 24(2), 20.
  - 8 Suluh, S., Musadat, A.R., Djafar, Z., Amaliyah, N. & Piarah, W.H. (2019). The Efficiency of Steel Plate Biomass Briquette Stove with Variation of Aluminum Cylinder Diameter. *Journal of Chemical Information and Modeling*, 100–106.
  - 9 Djafar, Z., Suluh, S., Amaliyah, N., Piarah, W.H. (2022). Comparison of the Performance of Biomass Briquette Stoves on Three Types of Stove Wall Materials. *International Journal of Design & Nature and Ecodynamics*, 17(1), 145–149. doi: 10.18280/ijdne.170119.
  - 10 Djafar, Z., Suluh, S., Isra, M., Amaliyah, N. (2021). The Performance of Clay Furnace with Variation in the Diameters of the Briquette Burning Chamber. *IOP Conference Series: Materials Science and Engineering*, 2020, vol. 875, no. 1, p. 6, doi: 10.1088/1757-899X/875/1/011001.
  - 11 Wang, J., Lou, H.H., Yang, F., & Cheng, F. (2016). Development and performance evaluation of a clean-burning stove, *J. Clean. Prod.*, 1–9. doi: 10.1016/j.jclepro.2016.01.068.
  - 12 Orhevba, P., Olatunji, B.A., O.I. & Obasa. (2018). Performance Evaluation of a Modified Briquette Stove, 3(2), 898–908.
  - 13 Tyagi, S.K., Pandey, A.K, Sahu, S., Bajala, V. & Rajput, J.P.S. (2013). Experimental study and performance evaluation of various cook stove models based on energy and exergy analysis. *J. Therm. Anal. Calorim.* 111(3), 1791–1799. doi: 10.1007/s10973-012-2348-9.
  - 14 Akolgo, G.A., Essandoh, E.O., Gyamfi, S., Atta-Darkwa, T., Kumi, E.N. & Maia, C. M. B. de F. (2018). The potential of a dual purpose improved cookstove for low income earners in Ghana–Improved cooking methods and biochar production. *Renew. Sustain. Energy Rev.* 82, May 2016, 369–379. doi: 10.1016/j.rser.2017.09.044.
  - 15 Guerrero, F., Arriagada, A., Muñoz, F., Silva, P., Ripoll, N., & Toledo, M. (2021). Particulate matter emissions reduction from residential wood stove using inert porous material inside its combustion chamber, *Fuel*, 289, November 2021. doi: 10.1016/j.fuel.2020.119756.
  - 16 Verma P. & Shukla, S.K. (2019). Performance evaluation of improved cook stove using briquette as fuel Performance Evaluation of Improved Cook Stove Using Briquette as Fuel, 020001, April, 2019.
  - 17 Rasoulkhani, M., Ebrahimi-Nik, M., Abbaspour-Fard, M.H. & A. Rohani. (2018). A Comparative evaluation of the performance of an improved biomass cook stove and the traditional stoves of Iran, *Sustain. Environ. Res.*, 28 (6), 438–443. doi: 10.1016/j.serj.2018.08.001.
  - 18 Murali, G., Channankaiah, Goutham, P., Hasan, I.E. & Anbarasan, P. (2015). Performance study of briquettes from agricultural waste for wood stove with catalytic combustor, *Int. J. ChemTech Res.*, 8(1), 30–36.
  - 19 Panwar, N.L. (2010). Performance Evaluation of Developed Domestic Cook Stove with *Jatropha Shell*, 309–314. doi: 10.1007/s12649-010-9040-8.
  - 20 Ahiduzzaman, M. & Islam, A.K.M.S. (2013). Development of biomass stove for heating up die barrel of rice husk briquette machine, *Procedia Eng.*, 56, 777–781. doi: 10.1016/j.proeng.2013.03.194.
  - 21 Djafar, Z., Salsabila A.Z. & Piarah, W.H. (2021). Performance Comparison Between Hot Mirror and Cold Mirror as a Beam Splitter on Photovoltaic - Thermoelectric Generator Hybrid Using LabVIEW Simulator. *International Journal of Heat and Technology*, 39(5), 1609–1617. <https://doi.org/10.18280/ijht.390524>.
  - 22 Kumar, M., Kumar, S. & Tyagi, S.K. (2013). Design, development and technological advancement in the biomass cookstoves: A review. *Renew. Sustain. Energy Rev.*, 26, 265–285. doi: 10.1016/j.rser.2013.05.010.
  - 23 Carty, N.M. & Bryden, K.M. (2014). A heat transfer model for the conceptual design of a biomass cookstove

- for developing countries. *Proc. ASME Des. Eng. Tech. Conf.*, 3 August 2014. doi: 10.1115/DETC2013-12650.
- 24 Sahu, K.B & Singh, R.K. (2014). Analysis of heat transfer and flow due to natural convection in air around heated triangular cylinders of different sizes inside a square enclosure," *Procedia Eng.*, 90, 550–556. doi: 10.1016/j.proeng.2014.11.771.
- 25 Ambreen, C.W.P.T. & Saleem, A. (2019). Pin-Fin Shape-dependent heat transfer and fluid flow characteristics of water and nanofluid-cooled micro pin-fin heat sinks square, circular, and triangular fin cross-sections. *Appl. Therm. Eng.*, 21(13-14), 1281–1282. doi: 10.1016/S1359-4311(01)00040-0.
- 26 Li, X., He, L., Qian, P., Huang, Z., Luo, C. & Liu, M. (2021). Heat transfer enhancement of droplet two-phase flow in cylindrical microchannel. *Appl. Therm. Eng.*, 186. doi: 10.1016/j.applthermaleng.2020.116474.

# The Performance of Clay-based Biomass Briquette Stove with Three Geometry Shape Variations

## ORIGINALITY REPORT

**21** %  
SIMILARITY INDEX

**17** %  
INTERNET SOURCES

**19** %  
PUBLICATIONS

**3** %  
STUDENT PAPERS

## PRIMARY SOURCES

- 1** [www.iieta.org](http://www.iieta.org)  
Internet Source **8** %
- 2** [www.researchgate.net](http://www.researchgate.net)  
Internet Source **4** %
- 3** Zuryati Djafar, Sallolo Suluh, Novriany Amaliyah, Wahyu H. Piarah. "Comparison of the Performance of Biomass Briquette Stoves on Three Types of Stove Wall Materials", International Journal of Design & Nature and Ecodynamics, 2022  
Publication **1** %
- 4** Z Djafar, N Amaliyah, S Suluh, M Isra, W H Piarah. "The Performance of Clay Furnace with Variation in the Diameters of the Briquette Burning Chamber", IOP Conference Series: Materials Science and Engineering, 2020  
Publication **1** %
- 5** Thomas Kirch, Cristian H. Birzer, Philip J. van Eyk, Paul R. Medwell. "Influence of Primary

and Secondary Air Supply on Gaseous Emissions from a Small-Scale Staged Solid Biomass Fuel Combustor", Energy & Fuels, 2018

Publication

---

6	<a href="http://autodocbox.com">autodocbox.com</a> Internet Source	1 %
7	<a href="http://eprints.itn.ac.id">eprints.itn.ac.id</a> Internet Source	1 %
8	<a href="http://repository.ukitoraja.ac.id">repository.ukitoraja.ac.id</a> Internet Source	1 %
9	Xinlong Li, Liqun He, Peng Qian, Zizhen Huang, Chengyuan Luo, Minghou Liu. "Heat transfer enhancement of droplet two-phase flow in cylindrical microchannel", Applied Thermal Engineering, 2020 Publication	<1 %
10	U. Omsakthivel, T. Lakshmanan, S. Sekar, B. Stalin. " Performance and emission characteristics of a micro-gasifier-based cook stove using solid biomass, and ", Transactions of the Canadian Society for Mechanical Engineering, 2021 Publication	<1 %
11	<a href="http://engj.org">engj.org</a> Internet Source	<1 %

---

12

Internet Source

&lt;1 %

13

Submitted to Occidental Mindoro State College

Student Paper

&lt;1 %

14

Indraneel J. Bhanap, Ramchandrada D. Deshmukh. "Development of an improved sawdust gasifier stove for industrial applications", Journal of Renewable and Sustainable Energy, 2012

Publication

&lt;1 %

15

Mohammadreza Sedighi, Hesamoddin Salarian. "A comprehensive review of technical aspects of biomass cookstoves", Renewable and Sustainable Energy Reviews, 2017

Publication

&lt;1 %

16

[link.springer.com](https://link.springer.com)

Internet Source

&lt;1 %

17

Okey Francis Obi, Michael E. Okechukwu, Kingsley C. Okongwu. "Energy and exergy efficiencies of four biomass cookstoves using wood chips", Biofuels, 2019

Publication

&lt;1 %

18

Raman, P., N.K. Ram, and J. Murali. "Improved test method for evaluation of bio-mass cookstoves", Energy, 2014.

&lt;1 %

19

docplayer.net

Internet Source

<1 %

---

20

"Innovative Design, Analysis and Development Practices in Aerospace and Automotive Engineering", Springer Science and Business Media LLC, 2021

Publication

---

<1 %

---

Exclude quotes      On

Exclude matches      Off

Exclude bibliography      On